

Aero PILATES[®] Performer 296

Owner's Manual

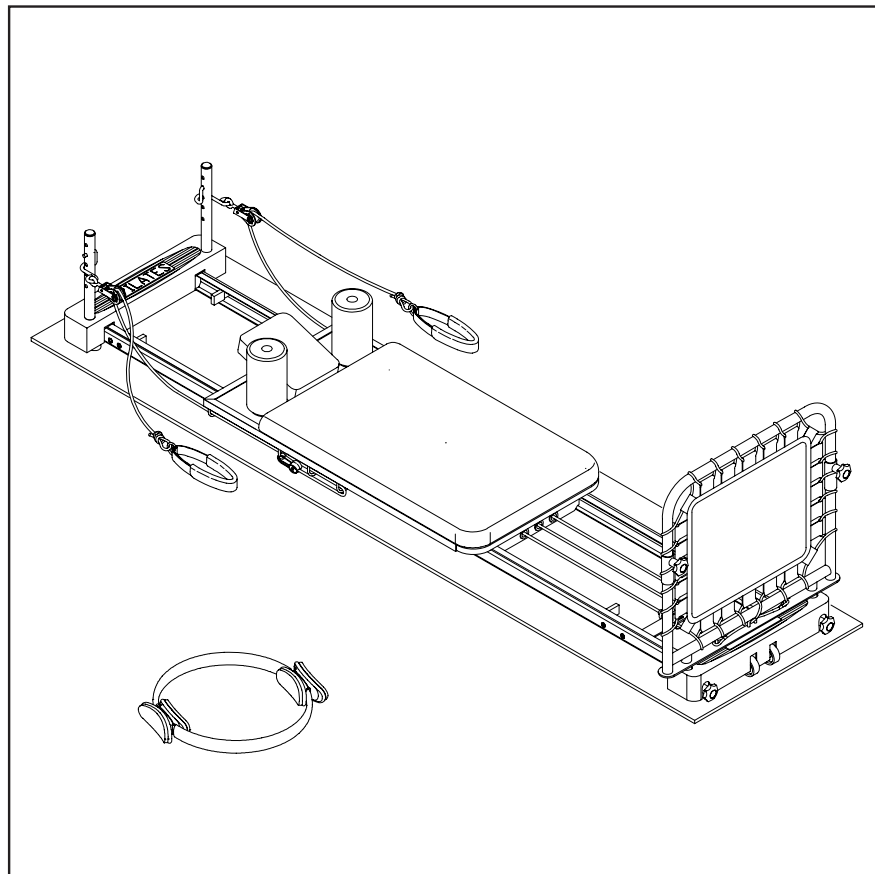

CAUTION:
Weight on this product should not exceed 300 lbs.

! WARNING !

Exercise can present a health risk. Consult a physician before beginning any exercise program with this equipment. If you feel faint or dizzy, immediately discontinue use of this equipment. Serious bodily injury can occur if this equipment is not assembled and used correctly. Serious bodily injury can also occur if all instructions are not followed. Keep others and pets away from equipment when in use. Always make sure all bolts and nuts are tightened prior to each use. Follow all safety instructions in this manual.

When calling for parts or service, please specify the following number.

55-4296

Pat. No. D382,319

**Other Patents Applied
and Are Pending**

MADE IN CHINA

**Product May Vary Slightly
From Pictured.**

This Product is Produced Exclusively by



2040 N. Alliance, Springfield, MO 65803

Customer Service Number

1 (800) 375-7520

www.staminaproducts.com

TABLE OF CONTENTS

	Page		Page
Safety Instructions	2	Conditioning Guidelines	11
Before You Begin	4	Warm-up and Cool-Down	12
Hardware Identification Chart	5	Warranty	13
Assembly Instructions	6	Product Parts Drawing	14
Operational Instructions	9	Parts List	15
Storage	10	Notes	17
Maintenance	10	Fax/Mail Ordering Form	18

SAFETY INSTRUCTIONS

WARNING: To reduce the risk of serious injury, read the following Safety Instructions before using the Aero**PILATES**.

1. Read all warnings posted on the Aero**PILATES**.
2. We recommend that two people be available for assembly of this product.
3. Read this Owner's Manual and follow it carefully before using the Aero**PILATES**. Make sure that it is properly assembled and tightened before use.
4. When exercising on this product, do not exercise at an intensity that causes the product itself to move. This could result in damage to your joints and the product.
5. Keep children away from the Aero**PILATES**. Do not allow children to use or play on the Aero**PILATES**. Keep children and pets away from the Aero**PILATES** when it is in use.
6. It is recommended that you place this exercise equipment on the floor mat.
7. Set up and operate the Aero**PILATES** on a solid level surface. Do not position the Aero**PILATES** on loose rugs or uneven surfaces.
8. Inspect the Aero**PILATES** for worn or loose components prior to use.
9. Tighten/replace any loose or worn components prior to using the Aero**PILATES**.
10. Consult a physician prior to commencing an exercise program. If, at any time during exercise, you feel faint, dizzy, or experience pain, stop and consult your physician.
11. Follow your physician's recommendations in developing your own personal fitness program.
12. Always choose the workout which best fits your physical strength and flexibility level. Know your limits and train within them. Always use common sense when exercising.
13. Do not wear loose or dangling clothing while using the Aero**PILATES**.
14. Be careful to maintain your balance while using, mounting, dismounting, or assembling the Aero**PILATES**, loss of balance may result in a fall and serious bodily injury.
15. The Aero**PILATES** should not be used by persons weighing over 300 pounds.
16. The Aero**PILATES** should be used by only one person at a time.
17. The Aero**PILATES** is for consumer use only. It is not for use in public or semipublic facilities.

WARNING: Before starting any exercise or conditioning program you should consult with your personal physician to see if you require a complete physical exam. This is especially important if you are over the age of 35, have never exercised before, are pregnant, or suffer from any illness. **READ AND FOLLOW THE SAFETY PRECAUTIONS. FAILURE TO FOLLOW THESE INSTRUCTIONS CAN RESULT IN SERIOUS BODILY INJURY.**

CALL US FIRST



STAMINA[®]
CUSTOMER SERVICE NUMBER
1 (800) 375-7520

THANK YOU FOR PURCHASING THE
AeroPILATES

To help you get started, we have pre-assembled most of your Aero**PILATES** at the factory with the exception of those parts left unassembled for shipping purposes.

Simply follow the few assembly instructions set forth in this manual. Within a few minutes you will be getting your body into shape and on your way to achieving a happier and healthier lifestyle.

Should you have any questions,
please call our Customer Service Department toll-free number,
1 (800) 375-7520

Monday - Thursday, 7:30 A.M. - 5:00 P.M. Central Time.
Friday, 8:00 A.M. - 3:00 P.M., Central Time.



TELEPHONE
CUSTOMER SERVICE
Tel: 1 (800) 375-7520



FAX
CUSTOMER SERVICE
Fax: (417) 889-8064



ONLINE
CUSTOMER SERVICE
parts@staminaproducts.com
cust-srv@staminaproducts.com
www.staminaproducts.com



MAIL
STAMINA PRODUCTS, INC.
ATTN: Customer Service
P.O. Box 1071
Springfield, MO. 65801-1071

BEFORE YOU BEGIN

Thank you for choosing the **AeroPILATES**. We take great pride in producing this quality product and hope it will provide many hours of quality exercise to make you feel better, look better and enjoy life to its fullest.

Yes, it's a proven fact that a regular exercise program can improve your physical and mental health. Too often, our busy lifestyles limit our time and opportunity to exercise. The **AeroPILATES** provides a convenient and simple method to begin your assault on getting your body in shape and achieving a happier and healthier lifestyle.

Before reading further, please review the drawing below and familiarize yourself with the parts that are labeled.

Read this manual carefully before using the **AeroPILATES**.

Although Stamina constructs its products with the finest materials and uses the highest standards of manufacturing and quality control, there can sometimes be missing parts or incorrectly sized parts. If you any questions or problems with the parts included with your **AeroPILATES**, please do not return the product. Contact us **FIRST!**

If a part is missing or defective, please call us toll free at 1-800-375-7520 (in the U.S.). Our Customer Service Staff is available to assist you from 7:30 A.M. to 5:00 P.M. (Central Time) Monday through Thursday and 8:00 A.M. to 3:00 P.M. (Central Time) on Friday.

If you would like to contact us on-line, go to our website at www.staminaproducts.com and access the Customer Service section.

Be sure to have the name and model number of the product available when you contact us.

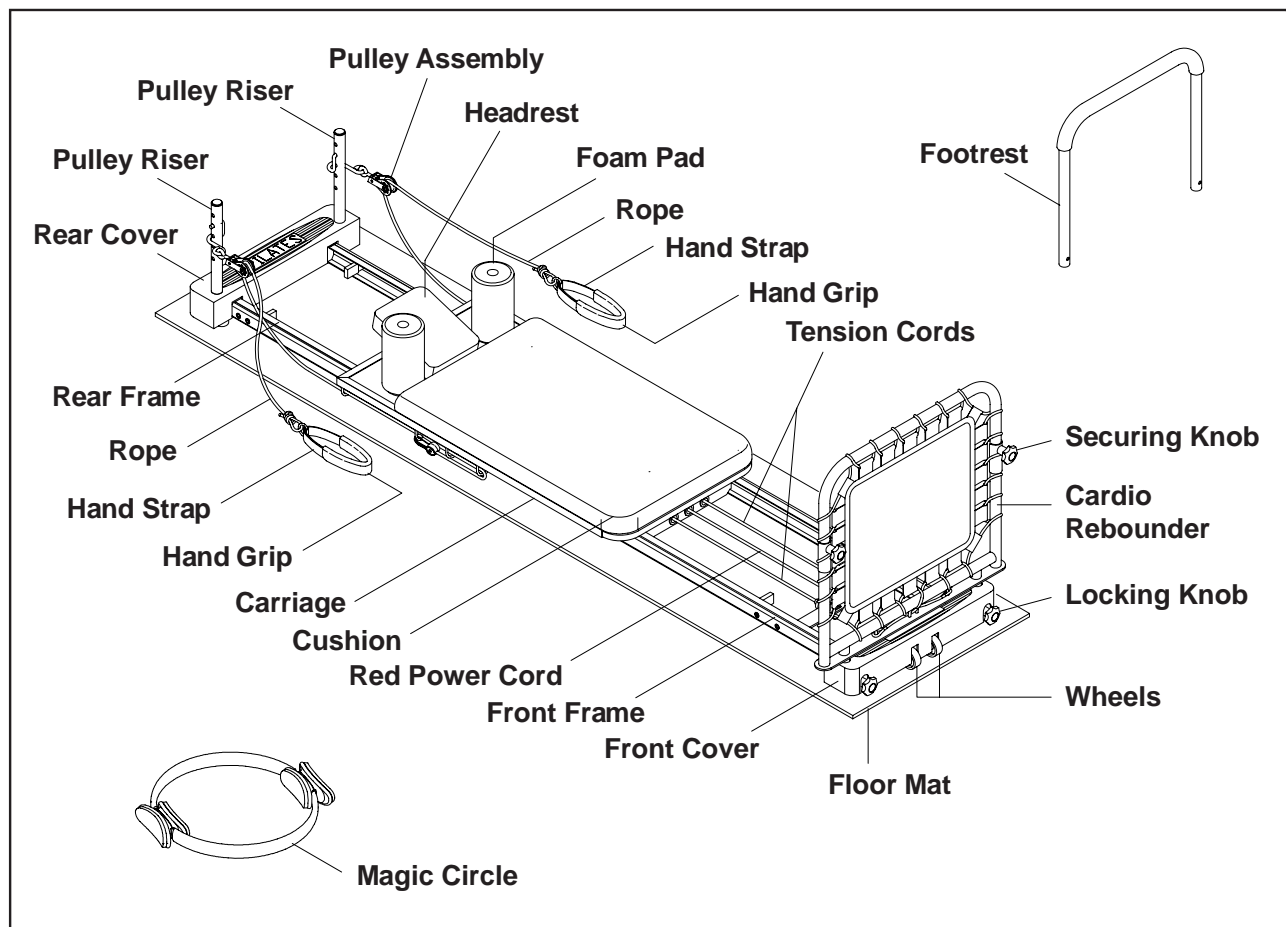

THE FOLLOWING TOOLS ARE REQUIRED FOR ASSEMBLY :



HARDWARE IDENTIFICATION CHART

This chart is provided to help identify the hardware used in the assembly process. Place the washers, the end of the bolts, or screws on the circles to check for the correct diameter. Use the small scale to check the length of the bolts and screws.

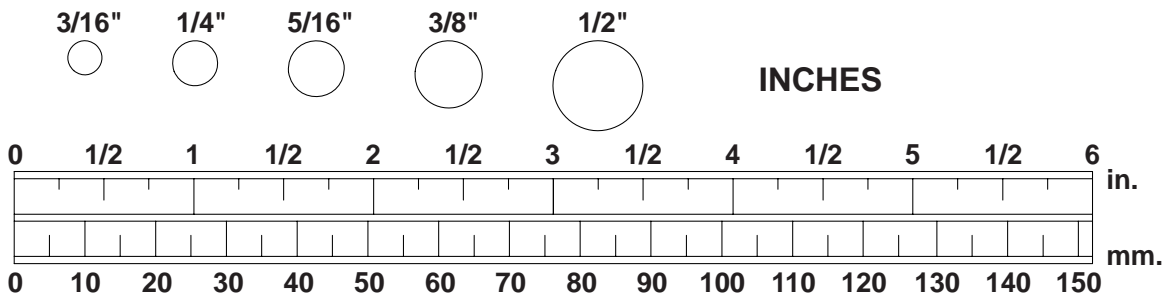

NOTICE: The length of all bolts and screws except those with flat heads is measured from below the head to the end of the bolt or screw. Flat head bolts and screws are measured from the top of the head to the end of the bolt or screw.

After unpacking the unit, open the hardware bag and make sure that you have all the following items. Some hardware may be already attached to the part.

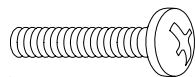

44	Screw, Round Head (M5 x 0.8 x 25mm)	4
61	Bolt, Round Head (M8 x 1.25 x 35mm)	2

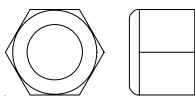

49	Nylon Nut (M8 x 1.25)	2
-----------	------------------------------	----------

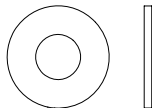

53	Washer (M8)	6
-----------	--------------------	----------

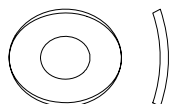

62	Arc Washer (M8)	2
-----------	------------------------	----------

ASSEMBLY INSTRUCTIONS

Place all parts from the box in a cleared area and position them on the floor in front of you. Remove all packing materials from your area and place them back into the box. Do not dispose of the packing materials until assembly is completed. Read each step carefully before beginning. If you are missing a part please call our toll-free number for assistance **1 (800) 375-7520** or e-mail us at:

parts@staminaproducts.com

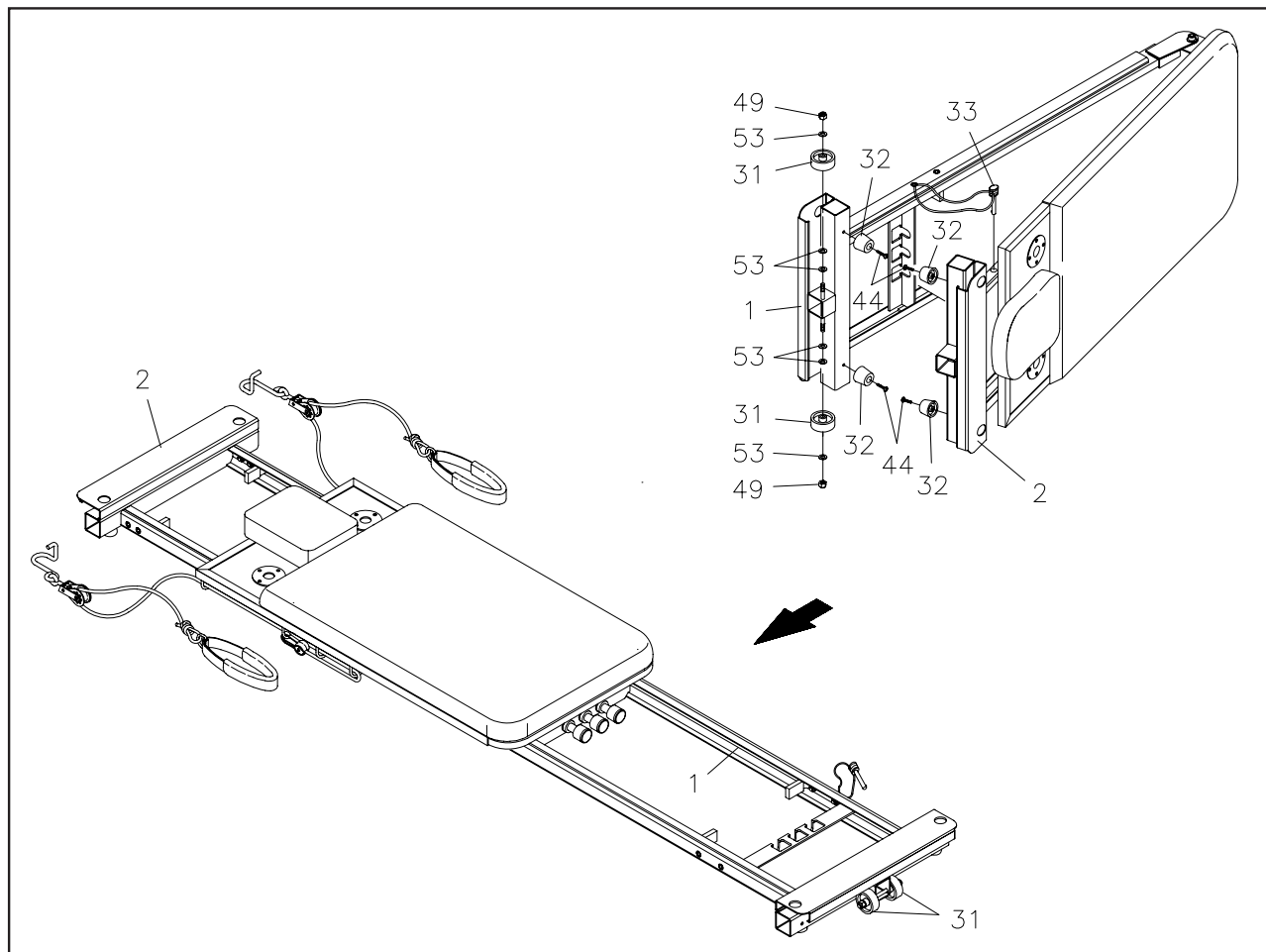

STEP 1

Remove your **AeroPILATES** from its packaging placing the product on its side, with the **LOCKING PIN(33)** side upward. Remove the **LOCKING PIN(33)** and unfold the **MAIN FRAME ASSEMBLY** separating the half that has the attached **LOCKING PIN(33)**. When completed, the frame should be separated approximately 3 feet at the end.

STEP 2

Attach the four **RUBBER FEET(32)** to the **FRONT FRAME(1)** and **REAR FRAME(2)** with **ROUND HEAD SCREWS(M5x0.8x25mm)(44)**. Attach the **WHEELS(31)** onto the **FRONT FRAME(1)** with **WASHERS(M8)(53)** and **NYLOCK NUTS(M8)(49)**.

STEP 3

Unfold your **AeroPILATES** to a flat position by moving the **FRONT FRAME(1)** away from the platform end of the product in a clockwise position until fully extended.

ASSEMBLY INSTRUCTIONS

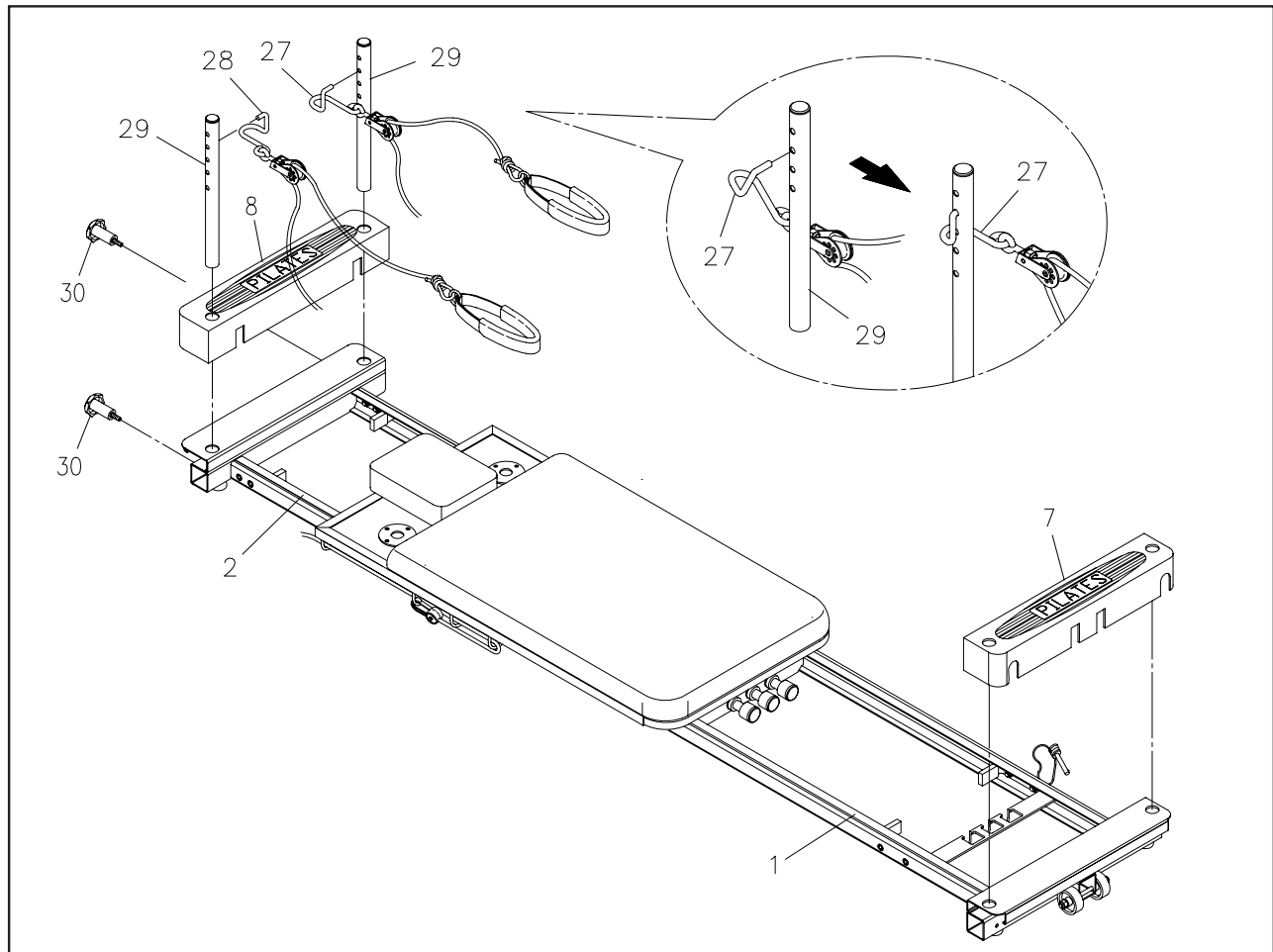

STEP 4

Remove the paper covering from the foam tape inside the **FRONT COVER(7)** and **REAR COVER(8)**. Place the **FRONT COVER(7)** over the **FRONT FRAME(1)**. Place the **REAR COVER(8)** over the **REAR FRAME(2)**. Press the covers securely in place.

STEP 5

Insert the **PULLEY RISERS(29)** into the mounting holes in the **REAR COVER(8)** and **REAR FRAME(2)**. Insert the **PULLEY RISERS(29)** all the way to the bottom, align the threaded holes in the **PULLEY RISERS(29)** with the holes in the **REAR FRAME(2)**, and lock the **PULLEY RISERS(29)** in position with the **LOCKING KNOBS(30)**.

STEP 6

Refer to the detail drawing above showing an enlarged view of the left **PULLEY RISER(29)** and the **LEFT PULLEY HOOK(27)**. With the pulley facing down, insert the **LEFT PULLEY HOOK(27)** into the left **PULLEY RISER(29)** from the inside as shown. Swing the pulley forward as shown and the **LEFT PULLEY HOOK(27)** will be in position for use. Use the same procedure to install the **RIGHT PULLEY HOOK(28)** on the right **PULLEY RISER(29)**.

ASSEMBLY INSTRUCTIONS

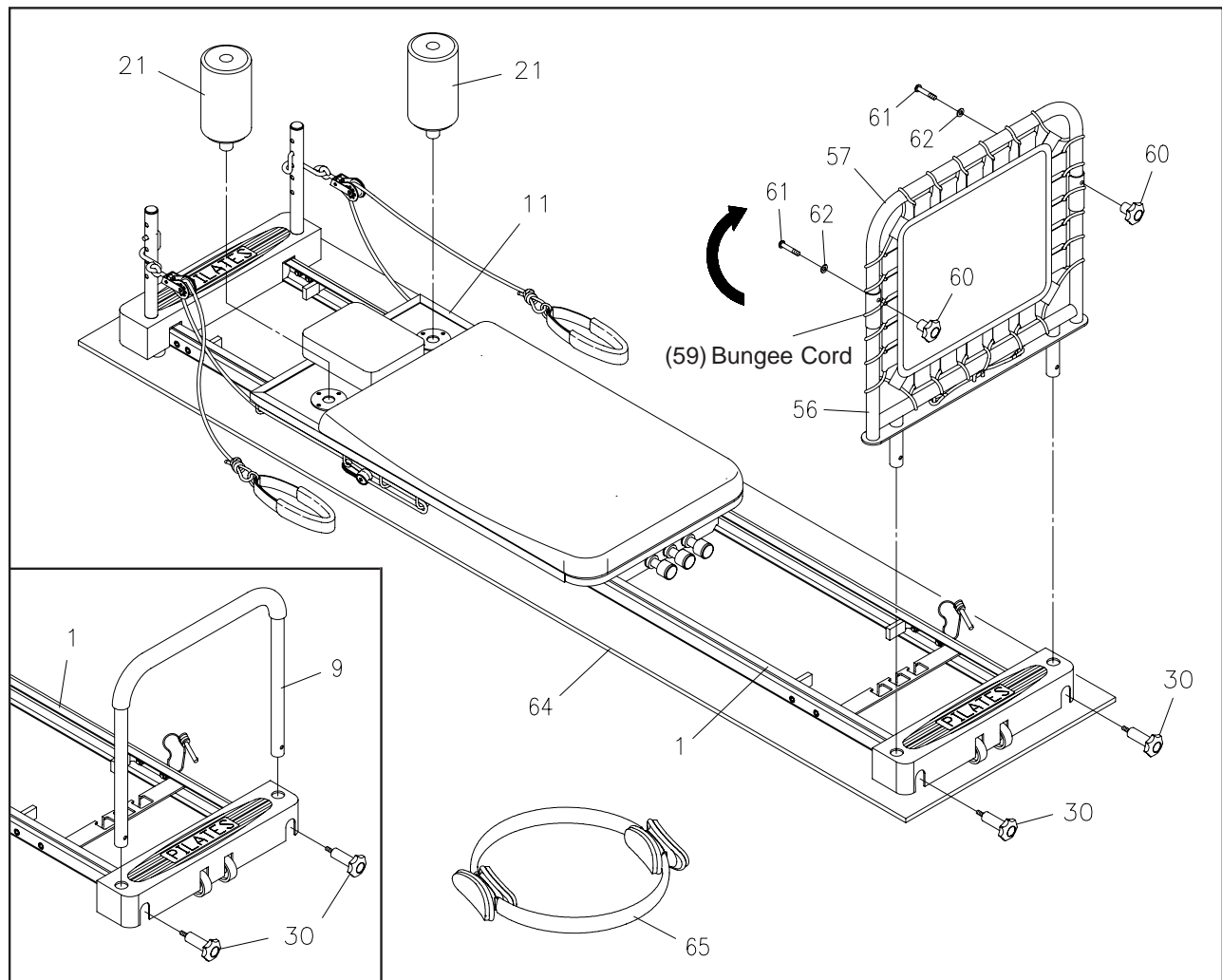

STEP 7

Insert the **FOAM PAD ASSEMBLIES(21)** into the holes located on the **CARRIAGE(11)**.

STEP 8

CAUTION: Be careful not to damage the **BUNGEE CORE(59)** when unfolding the **CARDIO REBOUNDER TOP FRAME(57)**.

Unfold the **CARDIO REBOUNDER** by swinging up the **CARDIO REBOUNDER TOP FRAME(57)** and securing with the **SECURING KNOBS(60)**, **ROUND HEAD BOLTS(M8x1.25x35mm)(61)**, and **ARC WASHERS(M8)(62)**.

STEP 9

Insert the **CARDIO REBOUNDER FRAME(56)** into the mounting holes located on the **FRONT FRAME(1)** and lock in position with the **LOCKING KNOBS(30)**.

NOTE: You can choose to Insert the **FOOTREST(9)** into the **FRONT FRAME(1)** and lock in position with the **LOCKING KNOBS(30)**. Refer to the inset drawing.

STEP 10

Place the Aero**PILATES** on the **FLOOR MAT(64)**. Now you are ready to workout with your Aero**PILATES**. Some of the exercises you will need to workout with the **MAGIC CIRCLE(65)**.

OPERATIONAL INSTRUCTIONS

LOAD ADJUSTMENT

There are two **TENSION CORDS(14)** and one heavier **RED POWER CORD(15)**.

The resistance of the **CARRIAGE(11)** can be adjusted by securing the **TENSION CORDS(14, 15)** in the slots located on the **FRONT FRAME(1)**. You can achieve various levels of resistance by securing different numbers of the **TENSION CORDS(14, 15)** in the slots.

NOTE: To achieve greater resistance in the **RED POWER CORD(15)** and **TENSION CORDS(14)**, stretch and re-tie the tension cords in a more taut position.

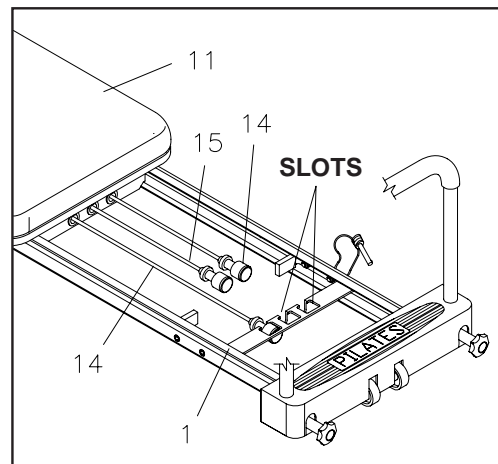

ROPE LENGTH ADJUSTMENT

The **ROPES(22)** are wrapped on the **HOOKS** located on both sides of the **CARRIAGE(11)**. You can adjust the length between the **PULLEY ASSEMBLY(26)** and the **HAND STRAP(24)** by attaching the **PLASTIC HOOKS(23)** onto different **HOOKS**.

- 1. Arm Function:** To position the **HAND STRAP(24)** close to the **PULLEY ASSEMBLY(26)**, hook the **PLASTIC HOOK(23)** onto the **HOOKS** which will shorten the **ROPE(22)**.
- 2. Leg Function:** To achieve a full range of movement, hook the **PLASTIC HOOK(23)** of the rope onto the desired **A, B, or C** hook.

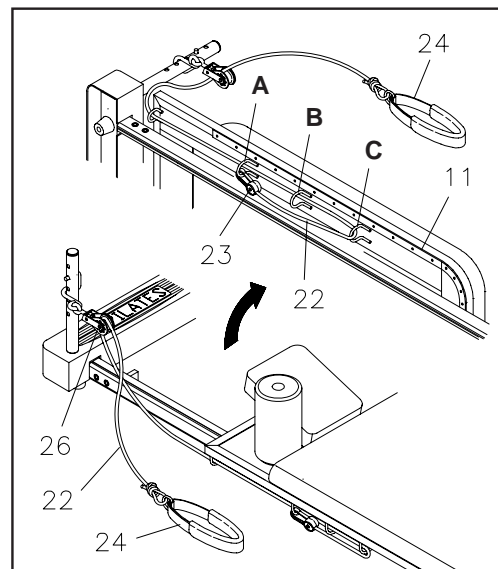

HEADREST ADJUSTMENT

The **HEADREST(19)** on the **CARRIAGE(11)** can be positioned at an incline by simply pivoting the **SUPPORT BRACKET** underneath the **HEADREST(19)**.

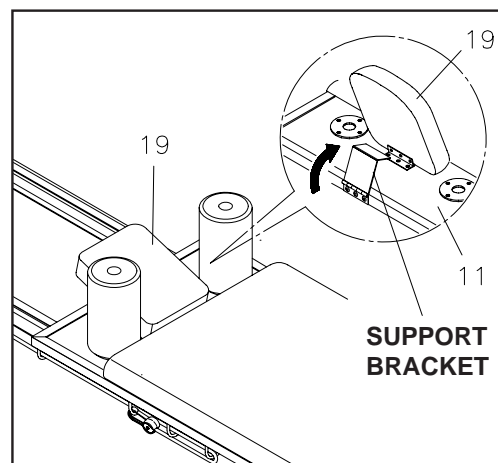

STORAGE

1. To store the Aero**PILATES** simply keep it in a clean dry place.
2. Move the Aero**PILATES** with the moving wheels on the **FRONT FRAME(1)**. Grasp on the back end of the **REAR FRAME(2)** to move the Aero**PILATES**.

MAINTENANCE

The safety and integrity designed into the Aero**PILATES** can only be maintained when the Aero**PILATES** is regularly examined for damage and wear. Special attention should be given to the following:

1. It is the sole responsibility of the user/owner to ensure that regular maintenance is performed.
2. Worn or damaged components shall be replaced immediately or the Aero**PILATES** removed from service until repair is made.
3. Verify that the **ROPES(22)** are properly installed on the **PULLEY ASSEMBLYS(26)**.
4. Check the condition of the **ROPES(22)**. Replace the Rope if it is cracked or broken.
5. Check the **PLASTIC HOOKS(23)** on the ends of the **ROPES(22)**. Replace the Ropes with deformed or damaged hooks.
6. Check the **TENSION CORDS(14)** and **RED POWER CORD(15)** for wear. Replace the Cords that are frayed or worn.
7. Check the **BUNGEE CORD(59)** on the **CARDIO REBOUNDER** for wear. Replace the **BUNGEE CORD (59)** if it is frayed or worn.
8. Check the pulleys for excessive wear. Replace worn pulleys.
9. Check the **HAND GRIPS(25)** for damage. Replace damaged parts.
10. Check and clean the rollers and the rolling surfaces on the rail. Clean by wiping with a dry cloth.
11. Verify that the **WARNING LABEL(63)** is in place and easy to read. Call Stamina Products immediately (1-800-375-7520) for a replacement **WARNING LABEL(63)** if the **WARNING LABEL(63)** is missing or damaged.
12. Only Stamina Products supplied components shall be used to maintain/repair the Aero**PILATES**.
13. Keep your Aero**PILATES** clean by wiping with an absorbent cloth after use.

CONDITIONING GUIDELINES

How you begin your exercise program depends on your physical condition. If you have been inactive for several years or are severely overweight, start slowly and increase your workout time gradually. Increase your workout intensity gradually, too, by monitoring your heart rate while you exercise.

Remember to follow these essentials:

- Have your doctor review your training and diet programs.
- Begin your training program slowly with realistic goals that have been set by you and your physician.
- Warm up before you exercise and cool down after you work out.
- Take your pulse periodically during your workout and strive to stay within a range of 60% (lower intensity) to 90% (higher intensity) of your maximum heart rate zone. Start at the lower intensity and build up to higher intensity as you become more aerobically fit.
- If you feel dizzy or lightheaded you should slow down or stop exercising.

Initially you may only be able to exercise within your target zone for a few minutes; however, your aerobic capacity will improve over the next six to eight weeks. It is important to pace yourself while you exercise so you don't tire too quickly.

To determine if you are working out at the correct intensity, use a heart rate monitor or use the table below. For effective aerobic exercise, your heart rate should be maintained at a level between 60% and 90% of your maximum heart rate. If just starting an exercise program, work out at the low end of your target heart rate zone. As your aerobic capacity improves, gradually increase the intensity of your workout by increasing your heart rate.

Measure your heart rate periodically during your workout by stopping the exercise but continuing to move your legs or walk around. Place two or three fingers on your wrist and take a six second heartbeat count. Multiply the results by ten to find your heart rate. For example, if your six second heartbeat count is 14, your heart rate is 140 beats per minute. A six second count is used because your heart rate will drop rapidly when you stop exercising. Adjust the intensity of your exercise until your heart rate is at the proper level.

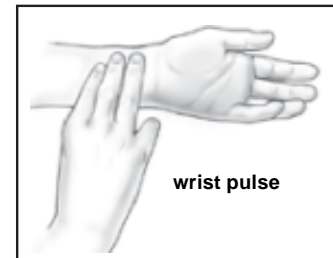

Target Heart Rate Zone Estimated by Age*

Age	Target Heart Rate Zone (55%-90% of Maximum Heart Rate)	Average Maximum Heart Rate 100%
20 years	110-180 beats per minute	200 beats per minute
25 years	107-175 beats per minute	195 beats per minute
30 years	105-171 beats per minute	190 beats per minute
35 years	102-166 beats per minute	185 beats per minute
40 years	99-162 beats per minute	180 beats per minute
45 years	97-157 beats per minute	175 beats per minute
50 years	94-153 beats per minute	170 beats per minute
55 years	91-148 beats per minute	165 beats per minute
60 years	88-144 beats per minute	160 beats per minute
65 years	85-139 beats per minute	155 beats per minute
70 years	83-135 beats per minute	150 beats per minute

* For cardiorespiratory training benefits, the American College of Sports Medicine recommends working out within a heart rate range of 55% to 90% of maximum heart rate. To predict the maximum heart rate, the following formula was used: $220 - \text{Age} = \text{predicted maximum heart rate}$

WARM-UP and COOL-DOWN

Warm-up The purpose of warming up is to prepare your body for exercise and to minimize injuries. Warm up for two to five minutes before strength-training or aerobic exercising. Perform activities that raise your heart rate and warm the working muscles. Activities may include brisk walking, jogging, jumping jacks, jump rope, and running in place

Stretching Stretching while your muscles are warm after a proper warm-up and again after your strength or aerobic training session is very important. Muscles stretch more easily at these times because of their elevated temperature, which greatly reduces the risk of injury. Stretches should be held for 15 to 30 seconds. Do not bounce.

Suggested Stretching Exercises

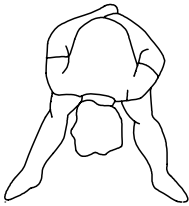

Lower Body Stretch

Place feet shoulder-width apart and lean forward. Keep this position for 30 seconds using the body as a natural weight to stretch the backs of the legs. **DO NOT BOUNCE!** When the pull on the back of the legs lessen, try a lower position gradually.



Floor Stretch

While sitting on the floor, open the legs as wide as possible. Stretch the upper body toward the knee on the right leg by using your arms to pull your chest to your thighs. Hold this stretch 10 to 30 seconds. **DO NOT BOUNCE!** Do this stretch 10 times. Repeat the stretch with the left leg.

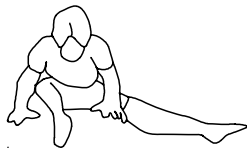

Bent Torso Pulls

While sitting on the floor, have legs apart one leg straight and one knee bent. Pull the chest down to touch the thigh on the leg that is bent and twist at the waist. Hold this position at least 10 seconds. Repeat 10 times on each side.

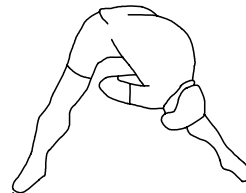
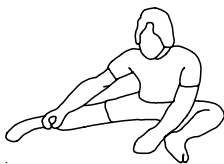

Bent Over Leg Stretch

Stand with feet shoulder-width apart and lean forward as illustrated. Using the arms, **gently** pull the upper body towards the right leg. Let the head hang down. **DO NOT BOUNCE!** Hold the position a minimum of 10 seconds. Repeat pulling the upper body to the left leg. Do this stretch several times slowly.

Remember always to check with your physician before starting any exercise program.

Cool-Down The purpose of cooling down is to return the body to its normal, or near normal, resting state at the end of each exercise session. A proper cool-down slowly lowers your heart rate and allows blood to return to the heart. Your cool-down should include the stretches listed above and should be completed after each strength-training session.

WARRANTY

Stamina Products, Inc. warrants that this product will be free from defects in materials and workmanship under normal use, service and proper operation for a period of 90 days on the parts and five years on the frame from the date of the original purchase from an authorized retailer. **THIS WARRANTY SHALL NOT APPLY TO ANY PRODUCT WHICH HAS BEEN SUBJECT TO COMMERCIAL USE, ABUSE, MISUSE, ALTERATION OF ANY TYPE OR CAUSE OR TO ANY DEFECT OR DAMAGE CAUSED BY REPAIR, REPLACEMENT, SUBSTITUTION OR USE WITH PARTS OTHER THAN PARTS PROVIDED BY STAMINA PRODUCTS, INC.** Commercial use includes use of the product in athletic clubs, health clubs, spas, gymnasiums, exercise facilities, and other public or semipublic facilities whether or not the product's use is in furtherance of a profit making enterprise, and all other use which is not for personal, family, or household purposes.

To implement this limited warranty, send a written notice stating your name, date, and place of purchase and a brief description of the defect along with your receipt to **Stamina Products, Inc. P.O. Box 1071, Springfield Missouri, USA, 65801-1071** or call us at **1 (800) 375-7520**. If the defect is covered under this limited warranty, you will be requested to return the product or part to us for free repair or replacement at our option. **NO ACTION FOR BREACH OF THIS LIMITED WARRANTY MAY BE COMMENCED MORE THAN ONE (1) YEAR AFTER THE DATE THE ALLEGED BREACH WAS OR SHOULD HAVE BEEN DISCOVERED. NO ACTION FOR BREACH OF ANY IMPLIED WARRANTY MAY BE COMMENCED MORE THAN ONE (1) YEAR AFTER DELIVERY OF THE PRODUCT TO THE PURCHASER.** This limited warranty is not transferable. **IF ANY PART OF THE PRODUCT IS NOT IN COMPLIANCE WITH THIS LIMITED WARRANTY OR ANY IMPLIED WARRANTY, THE REMEDY OF REPAIR OR REPLACEMENT IS THE EXCLUSIVE REMEDY AVAILABLE TO YOU.** In the event that the purchaser makes any claim under this limited warranty or any implied warranty, the Warrantor reserves the right to require the product to be returned for inspection, at the purchaser's expense, to the Warrantor's premises in Springfield, Missouri. Return of the enclosed warranty registration card is not required for warranty coverage, but is merely a way of establishing the date and place of purchase.

Stamina Products, Inc. **SHALL NOT BE LIABLE FOR THE LOSS OF USE OF ANY PRODUCT, LOSS OF TIME, INCONVENIENCE, COMMERCIAL LOSS OR ANY OTHER INDIRECT, CONSEQUENTIAL, SPECIAL OR INCIDENTAL DAMAGES DUE TO BREACH OF THE ABOVE WARRANTY OR ANY IMPLIED WARRANTY.**

This limited warranty is the only written or express warranty given by Stamina Products, Inc. This warranty gives you specific legal rights, and you may also have other legal rights which vary from state to state. **ANY OTHER RIGHT WHICH YOU MAY HAVE, INCLUDING ANY IMPLIED WARRANTY OR MERCHANTABILITY OR FITNESS FOR A PARTICULAR PURPOSE, IS LIMITED IN DURATION TO THE DURATION OF THIS WARRANTY.**

The laws in some jurisdictions restrict the rights of manufacturers and distributors of consumer goods to disclaim or limit implied warranties and consequential and incidental damages with respect thereto. If any such law is found to be applicable, the foregoing disclaimers and limitations of and on implied warranties and consequential and incidental damages with respect thereto shall be disregarded and shall be deemed not to have been made to the extent necessary to comply with such legal restriction.

PRODUCT PARTS DRAWING

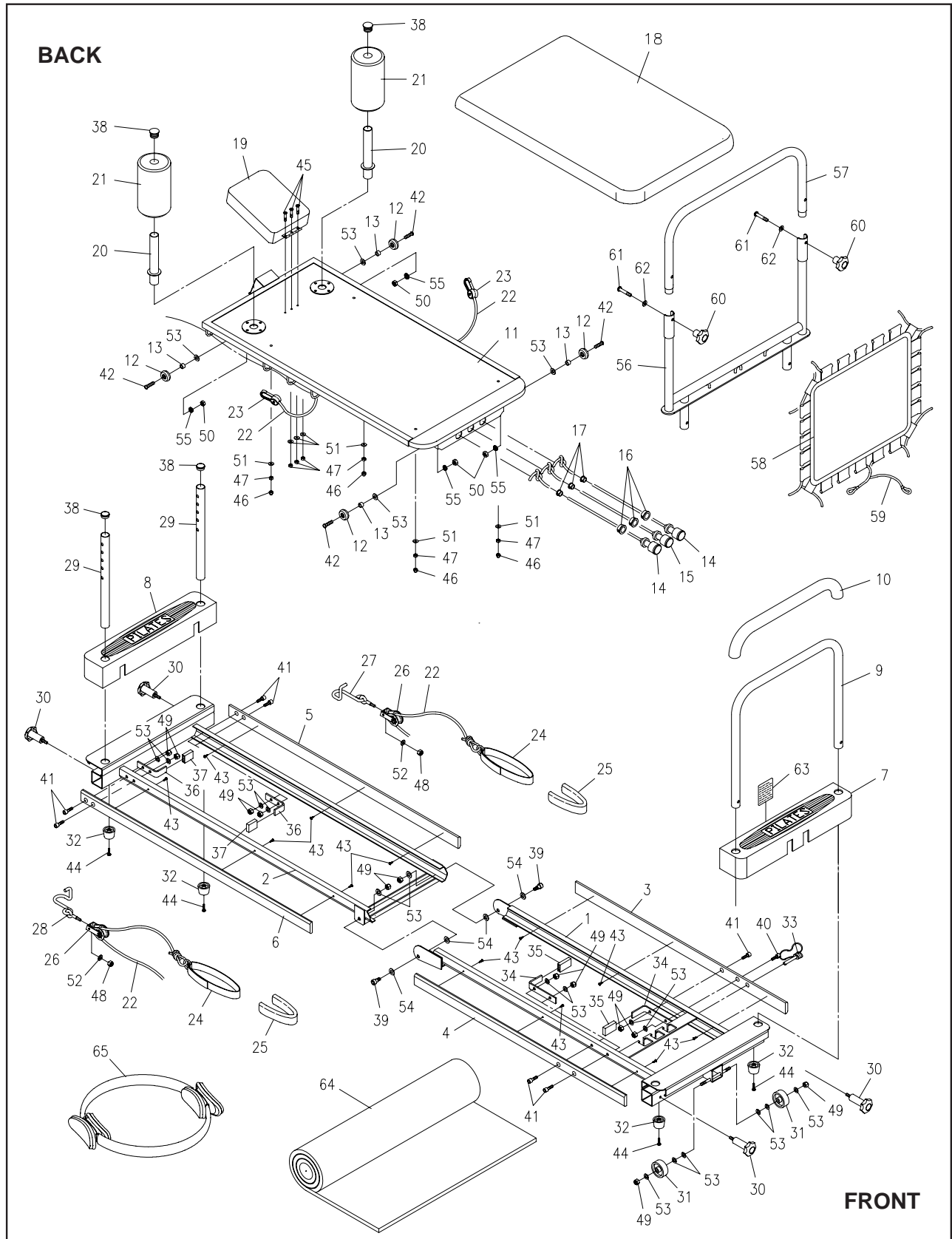

PARTS LIST

DIAGRAM#	PART NAME	QTY
1	Front Frame	1
2	Rear Frame	1
3	Front Left Side Rail	1
4	Front Right Side Rail	1
5	Rear Left Side Rail	1
6	Rear Right Side Rail	1
7	Front Cover	1
8	Rear Cover	1
9	Footrest	1
10	Foam Sleeve	1
11	Carriage	1
12	Roller	4
13	Roller Spacer	4
14	Tension Cord	2
15	Red Power Cord	1
16	Support Bushing	3
17	Stop Bushing	3
18	Cushion	1
19	Headrest	1
20	Foam Pad Tube	2
21	Foam Pad	2
22	Rope	2
23	Plastic Hook	2
24	Hand Strap	2
25	Hand Grip	2
26	Pulley Assembly	2
27	Left Pulley Hook	1
28	Right Pulley Hook	1
29	Pulley Riser	2
30	Locking Knob	4
31	Wheel	2
32	Rubber Foot	4
33	Locking Pin	1
34	Stop Plate	2
35	Stop Pad	2
36	Small Stop Plate	2
37	Small Stop Pad	2
38	Round Plug (25mm)	2
39	Shaft Bolt, Socket Head (M8 x 1.25 x 20mm)	2
40	Bolt, Socket Head/w hole (M8 x 1.25 x 20mm)	1
41	Bolt, Socket Head (M8 x 1.25 x 20mm)	7
42	Bolt, Round Head (M8 x 1.25 x 25mm)	4
43	Screw, Round Head (M3.5 x 11mm)	12
44	Screw, Round Head (M5 x 0.8 x 25mm)	4
45	Screw, Flat Head (M5 x 0.8 x 25mm)	3
46	Acorn Nut (M5 x 0.8)	4
47	Nylock Nut (M5 x 0.8)	7
48	Nylock Nut (M6 x 1)	2

PARTS LIST

DIAGRAM#	PART NAME	QTY
49	Nylock Nut (M8 x 1.25)	12
50	Nut (M8 x 1.25)	4
51	Washer (M5)	7
52	Washer (M6)	2
53	Washer (M8)	20
54	Washer (M10)	4
55	Lock Washer (M8)	4
56	Cardio Rebounder Frame	1
57	Cardio Rebounder Top Frame	1
58	Rebounder Mat	1
59	Bungee Cord	1
60	Securing Knob	2
61	Bolt, Round Head (M8 x 1.25 x 35mm)	2
62	Arc Washer (M8)	2
63	Warning label	1
64	Floor Mat	1
65	Magic Circle	1
66	Combination Wrench	1
67	Socket Wrench	1
68	Manual	1
69	Workout Chart	1
70	AeroPilates Performer Level One Workout	1
71	AeroPilates Performer Cardio Workout	1
72	AeroPilates Performer Magic Circle Workout	1

NOTES

FAX/MAIL ORDERING FORM

Please do not return the product. For your convenience, Stamina has a Customer Service Department with a toll-free number. Should a part be missing or a defective part found, please call **1 (800) 375-7520** (in the U.S.) from 7:30 A.M. - 5:00 P.M. Central Time, Monday - Thursday and 8:00 A.M. - 3:00 P.M. on Friday or fill out the fax sheet ordering form below and fax it to **(417) 889-8064**. Our Customer Service Department will be able to assist you with your problem and the part will be mailed directly to your house.



TELEPHONE
 CUSTOMER SERVICE
 Tel: 1 (800) 375-7520



FAX
 CUSTOMER SERVICE
 Fax: (417) 889-8064



ONLINE
 CUSTOMER SERVICE
 parts@staminaproducts.com
 cust-srv@staminaproducts.com
 www.staminaproducts.com



MAIL
 STAMINA PRODUCTS, INC.
 ATTN: Customer Service
 P.O. Box 1071
 Springfield, MO. 65801-1071



Detach and Mail or Fax the Form Below



Stamina Products, Inc.
P.O. Box 1071
Springfield, MO 65801-1071

Mr./Ms: _____

Address: _____ Apt. #: _____

City: _____ State: _____ Zip Code: _____

IMPORTANT: We must have your phone number in order to process the order!

Phone #: () _____ Work Phone #: () _____

Date Purchased: _____

Model #: _____

Purchased From: _____

IMPORTANT: Before filling out the form below make sure you have the right information. Refer to the parts list to make sure you're ordering the right parts!

PART #	DESCRIPTION	QUANTITY
EXAMPLE: 1	Rear Unit Assembly	1