

SAVE THIS MANUAL
FOR
FUTURE REFERENCE

SEARS

OWNER'S
MANUAL

MODEL NO.
351.226712

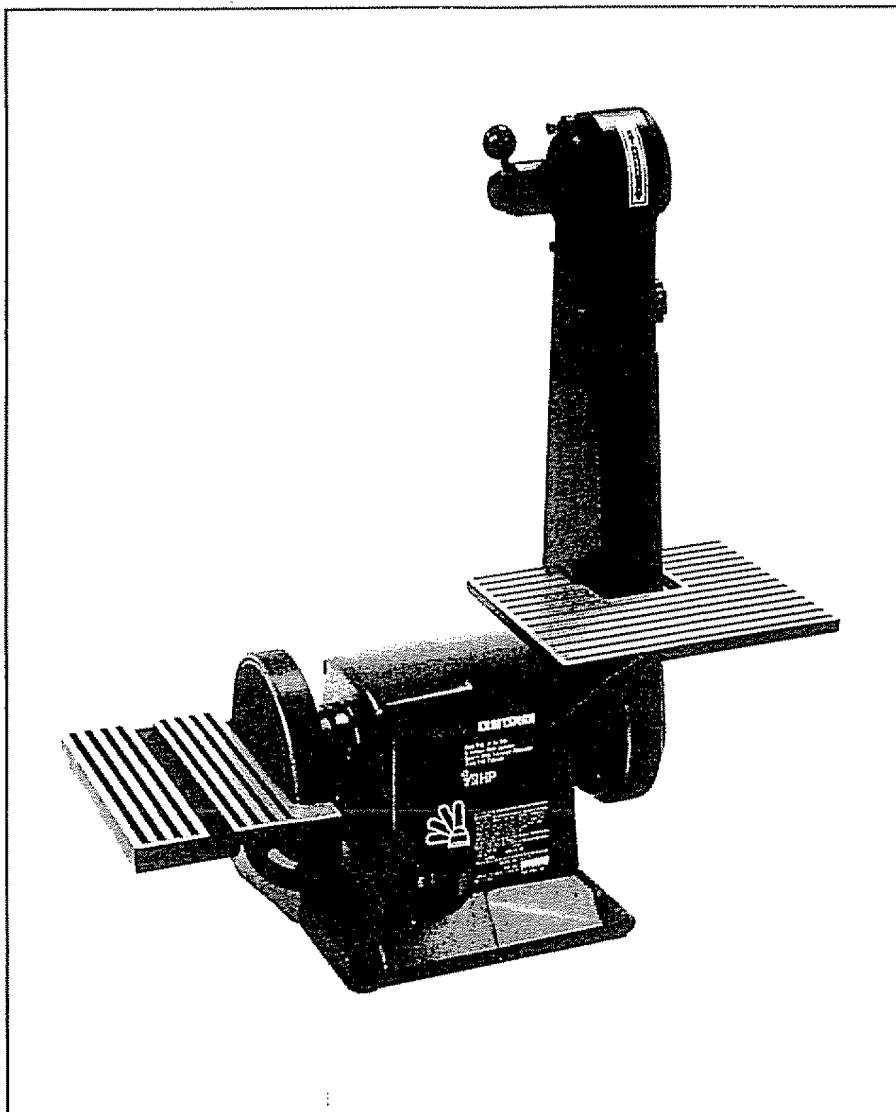

SEARS/CRAFTSMAN®

1x 6" Belt & Disc Sander

- *safety instructions*
- *operating instructions*
- *replacement parts*

CAUTION:

**READ ALL
INSTRUCTIONS
CAREFULLY!**

Sold by SEARS, ROEBUCK AND CO., Chicago, IL 60684 U.S.A. ©

Part No. 3899.01

AUGUST 1993

FULL ONE YEAR WARRANTY ON SEARS/CRAFTSMAN 1 x 6" BELT & DISC SANDER

If within one full year from the date of purchase, this Sears Craftsman 1 x 6" Belt & Disc Sander fails due to a defect in material or workmanship, Sears will repair it, free of charge.

WARRANTY SERVICE IS AVAILABLE BY SIMPLY CONTACTING THE NEAREST SEARS STORE OR SERVICE CENTER THROUGHOUT THE UNITED STATES.

This warranty gives you specific legal rights, and you may have other rights which vary from state to state.

SEARS, ROEBUCK AND CO., D817/WA, HOFFMAN ESTATES, IL 60179

GENERAL SAFETY INSTRUCTIONS FOR POWER TOOLS

BEFORE ANY WORK IS DONE READ THE CAUTIONS LISTED BELOW CAREFULLY. WORKING SAFELY PREVENTS ACCIDENTS.

OPERATOR SHOULD BE PREPARED FOR JOB:

- a. **Wear proper apparel.** Do not wear loose clothing, gloves, neckties, rings, bracelets or other jewelry which may get caught in moving parts of machine.
- b. **Wear protective hair covering** to contain long hair.
- c. **Wear safety shoes** with non-slip soles.
- d. **Wear safety glasses.** Everyday glasses have only impact resistant lenses. They are not safety glasses.
- e. **Wear face mask** or dust mask if sanding operation is dusty.
- f. **Be alert and think clearly.** Never operate power tools when tired, intoxicated or when taking medications that cause drowsiness.

WORK AREA SHOULD BE READY FOR JOB:

- a. **Keep work area clean.** Cluttered work areas and workbenches invite accidents.
- b. **Do not use power tools in dangerous environments.** Do not use power tools in damp or wet locations. Do not expose power tools to rain.
- c. **Work area should be properly lighted.**
- d. **Proper electrical outlet** should be available for tool. Three-prong plug should be plugged directly into properly grounded, three-prong receptacle.
- e. **Extension cords** should have a grounding prong and the three wires of the extension cord should be the correct gauge.
- f. **Keep visitors a safe distance** from work area.
- g. **Keep children out of workplace.** Make workshop child-proof. Use padlocks, master switches and remove starter keys to prevent any unintentional use of power tools.

TOOL SHOULD BE MAINTAINED:

- a. **Always unplug power tool** prior to inspection.
- b. **Consult owner's manual** for specific maintaining and adjusting procedures.
- c. **Use clean belts** and keep the tool clean for safest operation.
- d. **Remove adjusting keys and wrenches.** Form habit of checking to see that keys and adjusting wrenches are removed before turning tool on.

- e. **Keep all guards in place** and in working order.
- f. **Keep all parts in working order.** Check to determine that the guard or other parts will operate properly and perform their intended function.
- g. **Check for damaged parts.** Check for alignment of moving parts, binding of moving parts, breakage of parts, mounting and any other condition that may affect a tool's operation.
- h. **A guard or other part that is damaged should be properly repaired or replaced.** Do not perform makeshift repairs. (Use the parts list provided to order replacement parts.)

OPERATOR SHOULD KNOW HOW TO USE TOOL:

- a. **Use right tool for the job.** Do not force tool or attachment to do a job for which it was not designed.
- b. **Disconnect tool when changing accessories,** such as belt, disc, miter gauge and the like.
- c. **Avoid accidental start-up.** Make sure that the machine is in the "off" position before plugging in.
- d. **Do not force a tool.** It will work most efficiently at the rate for which it was designed.
- e. **Use recommended accessories.** Refer to page 11. Use of improper accessories may cause risk of injury to persons.
- f. **Handle the workpiece correctly.** Use miter gauge when required. Protect hands from possible injury.
- g. **Direction of feed.** Feed work into a belt or disc against direction of rotation of the belt or disc.
- h. **Turn the machine off if it jams.** Disconnect plug from power source before servicing tool.
- i. **Never leave a tool running unattended.** Turn the power off and do not leave sander until it comes to a complete stop.
- j. **Do not overreach.** Keep proper footing and balance.
- k. **Never stand on tool.** Serious injury could occur if tool is tipped or if abrasive belt or disc is unintentionally contacted.
- l. **Keep hands away** from moving parts and sanding surfaces.
- m. **Know your power tool.** Learn its operation, application and specific limitations.

CONTENTS

Warranty	2	Unpacking and Checking Contents	5
General Safety Instructions for Power Tools	2	Tools Needed	5
Safety Instructions for Belt & Disc Sander	3	Assembly	6
Motor Specifications and Electrical Requirements	4	Operation	6
Electrical Connections	4 & 5	Maintenance	8 & 9
		Trouble Shooting	9
		Replacement Parts Illustration	10
		Replacement Parts List	11

WARNING LABEL

The belt and disc sander has been marked with a warning label that needs to be observed for safe operation. The operator should be aware of the location and contents of this label.

This warning label is placed in a specific location so it is visible to the operator when starting and operating the belt and disc sander.

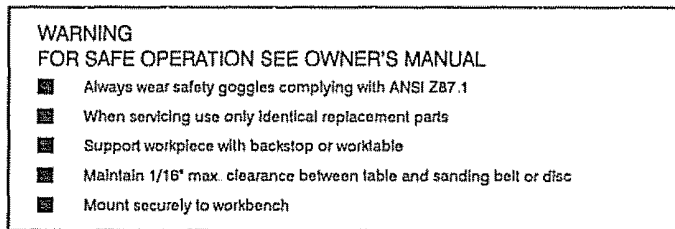

SAFETY INSTRUCTIONS FOR 1" x 6" BELT & DISC SANDER

WARNING: DO NOT ATTEMPT TO OPERATE BELT & DISC SANDER UNTIL IT IS COMPLETELY ASSEMBLED ACCORDING TO THE INSTRUCTIONS.

1. Know general power tool safety. Make sure all precautions are understood and provided for (page 2).
2. Secure all fasteners. Frequently check that nuts and bolts are tight and have not vibrated loose.
3. Follow operation instructions. Operate the belt and disc sander as described in this manual (pages 6 through 8).
4. Be sure motor runs clockwise on disc side. Abrasive belt must travel down.
5. Perform disc sanding on down side (right side). The disc should pull work towards the table.
6. Support workpiece. Use backstop or work table. The backstop for the abrasive belt is the belt platen (Key No. 25) as described in "Operating Instructions" (page 7).
7. Do not force work. Slowing or stalling the motor will overheat it.
8. Do not overheat work. Move metal across the abrasive and cool it when it becomes hot.
9. Do not wet grind or polish. Never use a steady stream of water on the workpiece. Only quench the workpiece in water to cool it.

10. Do not grind or polish magnesium. It could catch on fire.
11. Keep sander maintained. Follow "Maintenance Instructions" (page 9).
12. Disconnect power. Turn switch off and disconnect power whenever sander is not in use.

CAUTION: Be certain to follow proper operating procedures despite familiarity gained from frequent use of your belt and disc sander. Always remember that being careless for even a fraction of a second is sufficient time to inflict severe injury.

The operation of any power tool can result in foreign objects being thrown into the eyes, which can result in severe eye damage.

Always wear safety goggles complying with ANSI Z87.1 (shown on package) before commencing power tool operation. Safety goggles are available at Sears retail or catalog stores.

THINK SAFETY: Safety is a combination of operator common sense and alertness at all times when the belt & disc sander is being used.



MOTOR SPECIFICATIONS AND ELECTRICAL REQUIREMENTS

MOTOR

The belt and disc sander is assembled with motor and wiring installed as an integral part of the tool.

The 120 Volt AC permanent split capacitor motor has the following specifications:

Max. Developed Horsepower	1/2
Voltage	120
Amperes	4
Hertz	60
Phase	Single
RPM	3450
Rotation (viewed from left side)	Clockwise

POWER SOURCE

CAUTION: Do not connect the belt and disc sander to the power source until all assembly steps have been completed.

1. The motor is designed for operation on the voltage and frequency specified on motor nameplate.
2. Normal loads will be handled safely on voltages not more than 10% above or below nameplate voltage.
3. Running the unit on voltages which are not within range may cause overheating and motor burn-out.
4. Heavy loads require that voltage at motor terminals be not less than voltage specified on nameplate.

GROUNDING INSTRUCTIONS

This tool is equipped with a 3-conductor cord and ground type plug which has a grounding prong approved by Underwriters Laboratories and the Canadian Standards Association.

Do not remove or alter the grounding prong in any manner. In the event of a malfunction or breakdown, grounding provides a path of least resistance for electrical current to reduce the risk of electrical shock.

The plug must be plugged into a matching outlet that is properly installed and grounded in accordance with all local codes and ordinances.

Do not modify the plug provided. If it will not fit in the outlet, have the proper outlet installed by a qualified electrician. Improper connection of equipment-grounding conductor can result in a risk of electrical shock.

The conductor with insulation having an outer surface which is green is the equipment grounding conductor.

If repair or replacement of the electrical cord or plug is necessary, make sure the equipment grounding conductor is not connected to a line terminal.

WARNING: CHECK WITH A QUALIFIED ELECTRICIAN OR SERVICE PERSONNEL IF THE GROUNDING INSTRUCTIONS ARE NOT UNDERSTOOD OR IF IN DOUBT AS TO WHETHER TOOL IS PROPERLY GROUNDED.

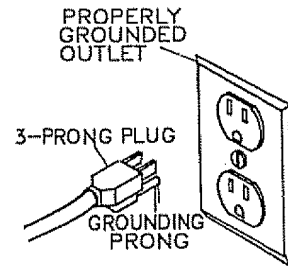

This tool is intended for use on a circuit having a nominal rating less than 150 volts which has an outlet that looks like the one illustrated above.

A temporary adapter, which looks like outlet illustrated below, may be used to connect this plug to a two-pole receptacle if a properly grounded outlet is not available.

The temporary adapter should be used only until a properly grounded outlet can be installed by a qualified electrician.

The green colored grounding lug extending from the adapter must be connected to a permanent ground such as a properly grounded outlet box.

Make sure adapter is connected to a known grounded receptacle

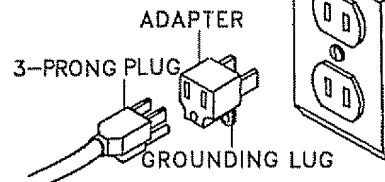

NOTE: The adapter illustrated is for use only if you already have a properly grounded 2-prong receptacle. Adapter is not allowed in Canada by the Canadian Electrical Code.

EXTENSION CORDS

1. The use of any extension cord will cause some drop in the voltage and loss of power.
2. Wires of extension cord must be sufficient in size to carry current and maintain adequate voltage.
3. Use the table below to determine the minimum wire size (A.W.G.) extension cord.
4. Use only 3-wire extension cords which have 3-prong grounding type plugs and 3-pole receptacles which accept the tool plug.
5. If power cord is worn, cut or damaged in any way, have it replaced immediately.

Extension cord length	Wire Size A.W.G.
Up to 100 ft.	16

NOTE: Using extension cords over 100 ft. long is not recommended.

WARNING: DO NOT PERMIT FINGERS TO TOUCH THE TERMINALS OF PLUGS WHEN INSTALLING OR REMOVING THE PLUG TO OR FROM OUTLET.

ELECTRICAL CONNECTIONS

WARNING: MAKE SURE THE UNIT IS OFF AND DISCONNECTED FROM THE POWER SOURCE BEFORE INSPECTING ANY WIRING.

The belt and disc sander electrical schematic is shown in Figure 1.

The motor and wiring are installed as shown in the wiring diagram (see Figure 1).

The motor is assembled with an approved three conductor cord to be used on 120 volts as indicated.

The power supply to the motor is controlled by a single pole locking rocker switch.

Remove the key to prevent unauthorized use.

The power lines are inserted directly onto the switch.

The green ground line must remain securely fastened to the frame to properly protect against electrical shock.

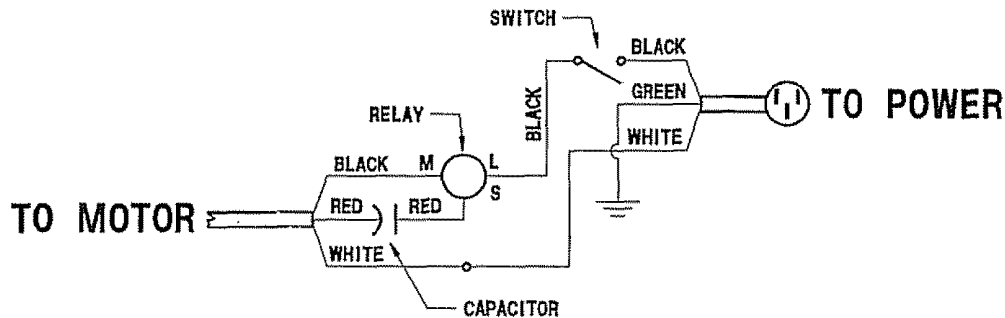

Figure 1

UNPACKING AND CHECKING CONTENTS

Check for shipping damages. If damage has occurred a claim should be filed with the carrier for fast action.

Parts listed below are not attached to sander and should be located and accounted for.

Refer to Figure 4, page 10.

- Key No. 13, 6mm-1.0 Hex nut, 2 each
- Key No. 54, 6mm Flat washer, 2 each
- Key No. 11, 6-1.0 x 20mm Socket head bolt, 2 ea.
- Key No. 5, Disc guard
- Key No. 8, Dust chute
- Key No. 12, #10-24 x 1/2" Pan head screw, 2 each
- Key Nos. 4-1 ea., 6-2 ea., 7-2 ea., 54- 2 ea., 10-1 ea., Disc table assembly
- Key No. 47, Belt table
- Key No. 49, 10-1.50 x 25mm Socket head bolt
- Key No. 50, 10mm Lock washer
- Key No. 51, 10mm Flat washer
- Key No. 48, Work stop

Unpainted steel surfaces have been coated with a shipping preservative. Remove the preservative with mineral spirits. Non-flammable solvents are recommended.

Use soap and water on rubber and plastic parts. Cleaning fluids tend to deteriorate them.

TOOLS NEEDED

While assembling or adjusting your belt & disc sander you will need the following tools:

1. 8 and 10mm Wrench
2. 3, 4, 6, and 8mm Hex Wrenches
3. Combination Square
4. Phillips Screwdriver

ASSEMBLY

CAUTION: DO NOT ATTEMPT ASSEMBLY IF PARTS ARE MISSING. USE OWNER'S MANUAL TO ORDER REPLACEMENT PARTS.

Refer to Figure 4.

ASSEMBLE DISC TABLE

Mount disc table (Key No. 4) to the disc guard (Key No. 5). Slide the pins located at the top, rear of the disc table into the L-shaped slots on either side of the disc guard. Slide the 1/4-20 x 1" carriage bolts (Key No. 6) into the square holes on either side of disc guard and through the slots in the table. Secure the carriage bolts with 2 each-6mm flat washers and wing nuts (Key Nos. 54 and 7)

Slide the disc guard over the 6" disc on the sander assembly. With the exhaust port to the rear of the sander, slide the dust chute (Key No. 8) onto the disc guard from below the 6" disc. Be sure that the mounting on the disc guard and the dust chute are aligned and secure the assembly with 2 each pan head screws (Key No. 12) and 2 each socket head bolts, washers and hex nuts (Key Nos. 11, 54 and 13).

Be sure that the gap between the disc and disc table is 1/16" or less. Secure guard and table position by tightening the socket head bolts and hex nuts (Key Nos. 11, 13 and 9).

ASSEMBLE BELT TABLE

Mount the belt table (Key No. 47) to the belt housing using a socket head bolt, lock washer and flat washer (Key Nos. 49, 50 and 51). Be sure that the gap between the belt table and belt is 1/16" or less. Tighten bolt securely.

The work stop (Key No. 48) can be used in place of the table. Remove table and mount work stop with bolt and washers. Be sure that the gap between the work stop and belt is 1/16" or less.

OPERATING INSTRUCTIONS

SAFETY PRECAUTIONS

WARNING: ALWAYS OBSERVE THE FOLLOWING SAFETY PRECAUTIONS.

Whenever adjusting or replacing any parts on the sander turn switch OFF and remove the plug from power source.

Recheck table locking nuts and bolts. They must be tightened securely.

Make sure all guards are properly attached. All guards should be fastened securely.

Make sure all moving parts are free and clear of any interference.

With power disconnected, test operation by hand for clearance and adjust if necessary.

Always wear eye protection or face shield.

Make sure abrasive belt always tracks properly. Correct tracking gives optimum performance.

After turning switch on, always allow the belt to come up to full speed before sanding or grinding.

Keep your hands clear of abrasive belt, disc and all moving parts.

For optimum performance do not stall motor or reduce belt speed. Do not force the work into the abrasive.

Never push a sharp corner of the workpiece rapidly against the belt or disc. The abrasive may tear.

Replace abrasives when they become loaded (glazed) or frayed.

When grinding metal move the workpiece across the abrasive to prevent heat build up.

Never attempt wet cutting. If the workpiece becomes too hot to handle, cool it in cold water.

TENSIONING ABRASIVE BELT

Tension is created by a spring loaded cam shaft (Key No. 57).

The tracking wheel is mounted on the opposite side of the shaft.

The spring tension is transmitted to the tracking wheel (Key No. 56) and maintains the tension on belt.

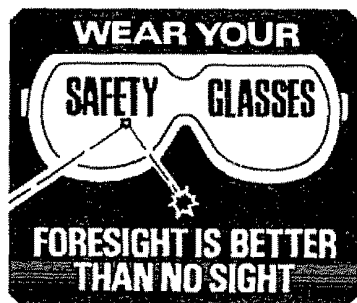

OPERATING INSTRUCTIONS (Continued)

REPLACING ABRASIVE BELT

Remove belt table (Key No. 47) by removing socket head bolt, lock washer and flat washer (Key Nos. 49, 50 & 51).

Remove the belt guard (Key No. 38) by removing thumb knobs (Key No. 36).

Release the tension on the belt by pulling the tension handle (Key No. 65) forward (towards operator).

Remove belt. The abrasive belt may have an arrow printed on the inside which indicates the direction of travel.

The arrow should point down toward the belt table to ensure that the splice in the belt will not come apart.

Pull on tension handle to install abrasive belt.

Place the abrasive belt squarely on the wheels.

The spring action will tension the belt.

Make sure the belt is tracking correctly. Adjust the tracking if necessary.

When the belt is tracking properly it rides on the center of each wheel.

Replace the belt guard and belt table.

TRACKING ABRASIVE

Test the tracking. Plug in power cord. Turn switch ON and immediately OFF.

If the abrasive belt did not move to the right or left, it is tracking properly.

If the belt moved to the right or left, adjustment is necessary.

To adjust the tracking wheel loosen the locknut (Key No. 66).

Use a 4mm hex wrench to turn the tracking adjusting bolt (Key No. 59).

If the abrasive belt moves to the left, turn the adjusting bolt counterclockwise.

Lock the position when the belt is tracking properly so the belt will remain centered on the wheels.

Hold the position of the tracking adjustment screw with the 4mm hex wrench.

Use a 8mm wrench to tighten locknut to lock position.

ADJUSTING BELT TABLE ANGLE

To adjust the angle of the belt table, loosen the socket head bolt (Key No. 49) and adjust to the desired angle.

Use a combination square to set the belt table at 45° or 90° to the abrasive belt.

Adjust for 1/16" clearance between the belt and the table.

When the belt table is at the desired angle, lock it into position by securely tightening the socket head bolt.

ABRASIVE BELT FINISHING

The abrasive belt can be used to sand wood, deburr metal, or polish plastic and glass.

The belt is most efficient when used with the table. The 1" belt size is convenient for getting into corners and concave curved edges.

ADJUSTING BELT PLATEN

Operating with the belt platen in place will allow the operator to sand or grind straight even lines.

The platen should be adjusted so the belt does not ride on the platen until work is fed into the belt.

To adjust belt platen, loosen two each socket head bolts (Key No. 53) and adjust. Tighten bolts securely.

POLISHING AND CONTOUR SANDING

Remove platen (Key No. 52) by removing socket head bolts and washers (Key Nos. 53 and 54).

The belt is flexible (no rigid back) and is able to follow the contour of curved parts.

Move the workpiece against belt. The belt will follow the contour (see Figure 2).

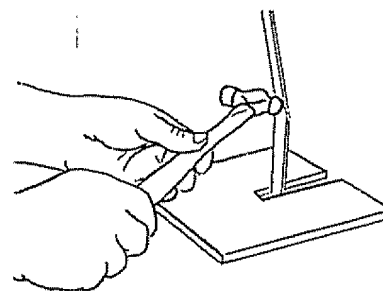

Figure 2

SHARPENING

Adjust belt table to the desired sharpening angle and tighten securely. Use the belt sander to notch the back of an auxiliary piece of wood.

Using a C-clamp, attach the auxiliary piece of wood to the table. It acts as a support while sharpening (see Figure 3).

Top edge of the wood should be approximately 1/16" from abrasive belt.

OPERATING INSTRUCTIONS (Continued)

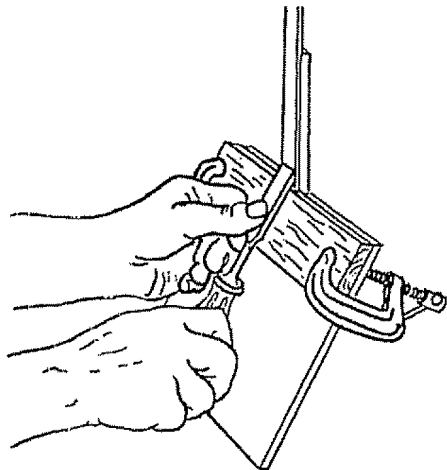

Figure 3

HORIZONTAL BELT SANDING

The belt housing can be tilted to a horizontal position.

Remove the belt table by removing the socket head bolt, lock washer and flat washer (Key Nos. 49, 50 & 51).

Loosen the socket head bolt (Key No. 46); tilt the belt housing to the horizontal position, and tighten the socket head bolt to secure the position.

The drive wheel of the belt can be used as contact wheel for sanding curved surfaces.

A workstop (Key No. 48) is provided to be used when straight sanding in the horizontal position.

Attach the workstop to the belt housing with socket head bolt, lock washer and washer (Key Nos. 49, 50 & 51).

Use a combination square to adjust the workstop at 90° to the belt with a 1/16" gap between the belt and workstop.

NOTE: For stability, mount the belt and disc sander to the bench top.

REPLACING THE ABRASIVE DISC

Remove disc table.

Remove old abrasive disc by peeling it from aluminum disc. Removing aluminum disc from motor shaft is not necessary.

Clean aluminum disc if necessary. Select the proper abrasive disc and apply to aluminum disc.

Also, abrasive used can be changed to a different grit by replacing the aluminum disc.

Additional aluminum discs are available. Use a separate aluminum disc for each grit size used.

Interchange the aluminum disc to change grit size.

Replace disc table.

ADJUSTING DISC TABLE ANGLE

The disc table is adjustable from 45° to 90° for beveled work.

To adjust the disc table, loosen the two knobs and adjust to the desired angle.

When disc table is at desired angle, lock it into position by securely tightening the knobs.

ABRASIVE DISC FINISHING

Abrasive disc sanding is well suited for finishing small flat surfaces and convex curved edges.

Move the workpiece across the down side (right) of the face of the abrasive disc.

The abrasive disc produces almost no abrasive action at the center.

The abrasive disc moves fastest and removes more material at the outer edge.

If workpiece is fed without additional guidance, more material will be removed towards the outer edge of the disc.

For accuracy use the miter gauge.

USING THE MITER GAUGE

(See Recommended Accessories, page 11.)

The miter gauge is used only on the disc table. Use the miter gauge for securing work and holding the proper angle while disc sanding.

Adjust the angle by repositioning the miter gauge scale and locking it into place with thumbscrew and flat washer

Check the accuracy of the miter gauge scale.

Use a combination square to adjust the miter gauge square to the face of the disc.

Indicator should be at zero. Loosen screw and reposition indicator if necessary.

MAINTENANCE

WARNING: MAKE CERTAIN THAT UNIT IS DISCONNECTED FROM POWER SOURCE BEFORE ATTEMPTING TO SERVICE OR REMOVE ANY COMPONENT.

CLEANING

Keep machine and workshop clean. Do not allow sawdust to accumulate on belt and disc sander.

Keep the wheels clean. Dirt on wheels will cause poor tracking and belt slippage.

IMPORTANT: AFTER SANDING WOOD OR NON-METALLIC MATERIAL, ALWAYS CLEAN THE AREA OF SAWDUST BEFORE GRINDING METAL. THE SPARKS COULD IGNITE THE DEBRIS AND CAUSE A FIRE.

MAINTENANCE (Continued)

LUBRICATION

The shielded ball bearings in this sander are permanently lubricated at the factory. They require no further lubrication.

KEEP SANDER IN REPAIR

If power cord is worn, cut or damaged in any way, have it replaced immediately.

Replace worn abrasives when needed.

Replace any damaged or missing parts. Use the parts list to order parts.

Any attempt to repair the motor may create a hazard unless repair is done by a qualified service technician. Repair service is available at your nearest Sears store.

TROUBLESHOOTING

SYMPTOM	POSSIBLE CAUSE(S)	CORRECTIVE ACTION
Motor will not start.	<ol style="list-style-type: none"> 1. Low voltage. 2. Open circuit in motor or loose connections. 	<ol style="list-style-type: none"> 1. Check power line for proper voltage. 2. Inspect all lead connections on motor for loose or open connection.
Motor will not start; fuses or circuit breakers blow.	<ol style="list-style-type: none"> 1. Short circuit in line cord or plug. 2. Short circuit in motor or loose connections. 3. Incorrect fuses or circuit breakers in powerline. 	<ol style="list-style-type: none"> 1. Inspect line cord or plug for damaged insulation and shorted wires. 2. Inspect all lead connections on motor for loose or shorted terminals or worn insulation on wires. 3. Install correct fuses or circuit breakers.
Motor fails to develop full power (power output of motor decreases rapidly with decrease in voltage at motor terminals).	<ol style="list-style-type: none"> 1. Power line overloaded with lights, appliances and other motors. 2. Undersize wires or circuits too long. 3. General overloading of power company's facilities. 	<ol style="list-style-type: none"> 1. Reduce the load on the power line. 2. Increase wire sizes, or reduce length of wiring. 3. Request a voltage check from the power company.
Motor overheats.	<ol style="list-style-type: none"> 1. Motor overloaded. 2. Air circulation through the motor restricted. 	<ol style="list-style-type: none"> 1. Reduce load on motor. 2. Clean out motor to provide normal air circulation through motor.
Motor stalls (resulting in blown fuses or tripped circuit).	<ol style="list-style-type: none"> 1. Short circuit in motor or loose connections. 2. Low voltage. 3. Incorrect fuses or circuit breakers in power line. 4. Motor overloaded. 	<ol style="list-style-type: none"> 1. Inspect connections in motor for loose or shorted terminals or worn insulation on wires. 2. Correct the low line voltage conditions. 3. Install correct fuses or circuit breakers. 4. Reduce load on motor.
Machine slows down while operating.	Applying too much pressure to workpiece.	Ease up on pressure.
Abrasive belt runs off top wheel.	Not tracking properly.	See Operating Instructions section "Tracking Abrasive Belt".

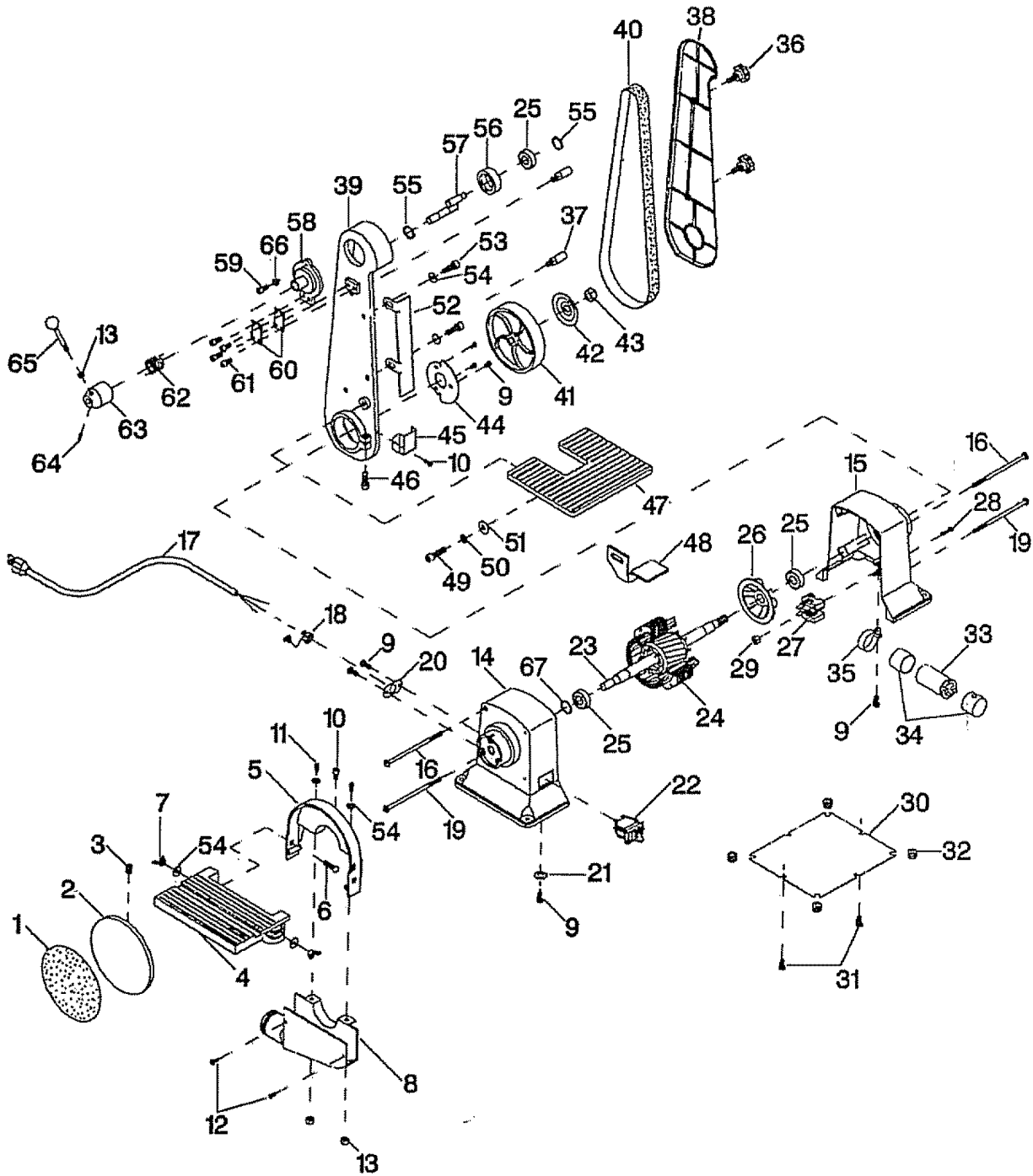

Figure 4—Replacement Parts Illustration

REPLACEMENT PARTS LIST

KEY NO.	PART NUMBER	DESCRIPTION	QTY	KEY NO.	PART NUMBER	DESCRIPTION	QTY
1	9 28309	● Abrasive disc	1	35	1606.00	Capacitor clamp	1
2	8285.00	Aluminum disc	1	36	8273.00	Knob	2
3	STD502502	*1/4-20 x 1/4" Set screw	1	37	8274.00	Stand off	2
4	8263.00	Disc table	1	38	8275.00	Belt cover	1
5	8264.00	Disc guard	1	39	8276.00	Belt housing	1
6	STD532510	*1/4-20 x 1" Carriage bolt	2	40	9 28410	● Abrasive belt 42"	1
7	STD541625	*1/4"-20 Wing nut	2	41	3318.00	Drive wheel	1
8	8265.00	Dust chute	1	42	0065.00	Wheel flange	1
9	STD511003	*#10-24 x 3/8" Pan head screw	8	43	0548.00	1/2"-12 Hex nut	1
10	6078.00	4-.70 x 12mm Socket head bolt	2	44	3317.00	Stop bracket	1
11	0179.00	6-1.0 x 20mm Socket head bolt	2	45	3193.01	Lower belt guard	1
12	STD511005	*#10-24 x 1/2" Pan head screw	2	46	0732.00	8-1.25 x 30mm Socket head bolt	1
13	STD840610	*6mm-1.0 Hex nut	3	47	8277.00	Belt table	1
14	8266.00	Motor housing (left)	1	48	3338.00	Work stop	1
15	8267.00	Motor housing (right)	1	49	1002.00	10-1.50 x 25mm Socket head bolt	1
16	8268.00	5-.80 x 135mm T.L. Pan hd. screw	2	50	STD852010	*10mm Lock washer	1
17	0067.00	Line cord	1	51	STD851010	*10mm Flat washer	1
18	1601.00	Strain relief	1	52	3319.00	Belt platen	1
19	8269.00	5-.80 x 142mm Pan head screw	2	53	3806.00	6-1.0 x 10mm Socket head bolt	2
20	8172.01	Strain relief plate	1	54	STD851006	*6mm Flat washer	6
21	STD551210	*#10 Serrated washer	1	55	STD582062	*3AMI-15mm Retaining ring Ext.	2
22	8066.00	Switch with key	1	56	8278.00	Tracking wheel	1
23	8270.00	Armature	1	57	8279.00	Tracking wheel cam	1
24	8271.00	Stator	1	58	8280.00	Tracking bracket	1
25	STD315225	*Bearing 6202ZZ	3	59	6045.00	5-.80 x 20mm Socket head bolt	1
26	1608.00	Motor fan	1	60	3327.01	Spring plate	2
27	5449.00	Relay	1	61	3855.00	5-.80 x 10mm Socket head bolt	4
28	8272.00	4-.70 x 32mm Pan head screw	1	62	3326.00	Tension spring	1
29	STD840407	*4mm-.70 Hex nut	1	63	8281.00	Spring cap	1
30	8067.00	Bottom cover	1	64	1043.00	6-1.0 x 8mm Set screw	1
31	STD511002	*#10-24 x 1/4" Pan head screw	2	65	8282.00	Handle assembly	1
32	4051.00	Rubber bumper	4	66	STD840508	*5mm-.80 Hex nut	1
33	0289.00	Capacitor	1	67	8283.00	Wavy washer	1
34	1607.00	Capacitor cap	2	**	3899.01	Owner's Manual	1

- See Recommended Accessories (below)
- * Standard hardware item available locally

- Always order by Part No.; Not by Key No.
- ** Not shown

RECOMMENDED ACCESSORIES

The Accessories are current and were available at the time this manual was printed.

ABRASIVE BELTS 1 x 42"

FINE..... 9 28409
MEDIUM..... 9 28410
COARSE..... 9 28411

ABRASIVE DISCS 6"

FINE..... 9 28308
MEDIUM..... 9 28309
COARSE..... 9 28310

MITER GAUGE.....9 24215
BELT CLEANER.....9 22744
MULTI PURPOSE STAND.....9 22250

SEARS

**OWNER'S
MANUAL**

SERVICE

**MODEL NO.
351.226712**

**HOW TO ORDER
REPAIR PARTS**

1 x 6" Belt & Disc Sander

Thank you for purchasing your Belt & Disc Sander from Sears. This unit will provide you with many years of reliable service. Should the need exist for repair parts or service, simply contact any Sears Service Center and most Sears, Roebuck and Co. stores. Be sure to provide all pertinent facts when you call or visit. The model number of your Belt & Disc Sander will be found on the front of the unit.

All parts listed may be ordered from any Sears Service Center and most Sears stores. If the parts you need are not stocked locally, your order will be electronically transmitted to the Sears Repair Parts Distribution Center for handling.

When ordering repair parts, always give the following information:

NAME OF ITEM: 1 X 6" Belt & Disc Sander

MODEL NUMBER: 351.226712

PART NUMBER:

PART DESCRIPTION:

Sold by SEARS, ROEBUCK AND CO., Chicago, IL 60684 U.S.A. ©

Part No. 3899.01

AUGUST 1993