



EFITMENT Magnetic Recumbent Bike w/ Pulse Monitor

MODEL NO.:

RB034

IMPORTANT! Read all instructions carefully before using this product. Save this manual for future reference.

**EXERCISE
EQUIPMENT
QUESTIONS:**

Contact customer service at

service@zoovaa.com

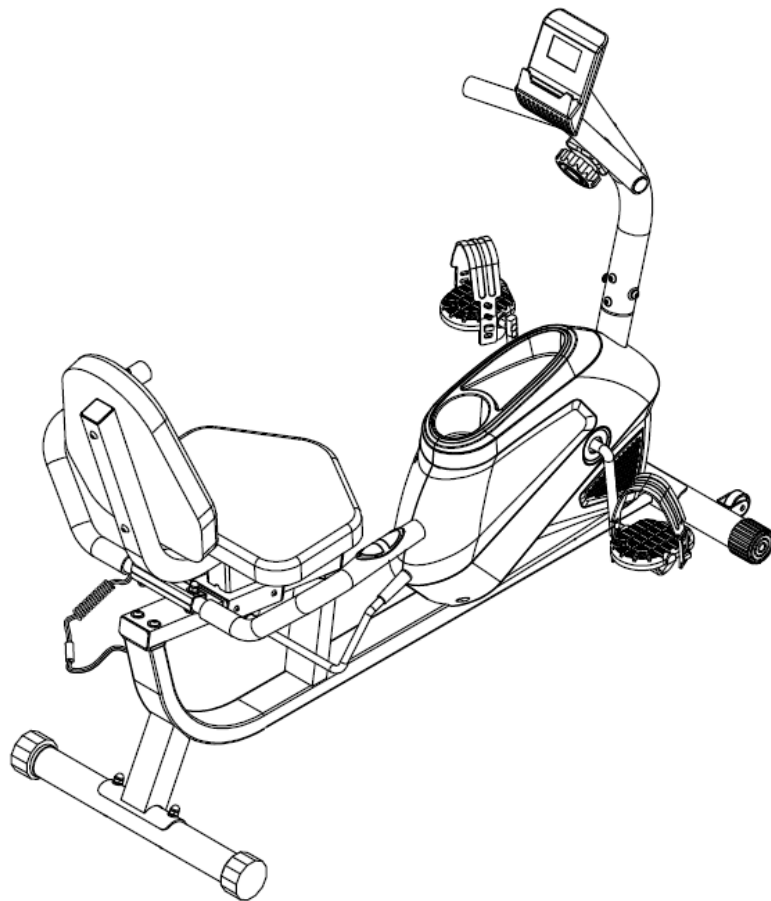

USER MANUAL

IMPORTANT SAFETY INSTRUCTIONS

At Efitment your safety is our top priority and to make sure both you and the unit remain in perfect working order, we encourage you to read all the instructions before assembling and using your new Efitment machine. Do not skip, substitute or modify any steps or procedures herein, as doing so could result in personal injury and will void your warranty.

1. Before starting any exercise program you should consult your physician to determine if you have any medical or physical conditions that could put your health and safety at risk or prevent you from using the equipment properly. Your physician's advice is essential if you are taking any medication that may affect your heart rate, blood pressure, or cholesterol level.
2. Be aware of your body's signals. Incorrect or excessive exercise can damage your health. Stop exercising if you experience any of the following symptoms: pain, tightness in your chest, irregular heartbeat, shortness of breath, lightheadedness, dizziness, or feelings of nausea. If you experience any of these conditions, you should consult your physician before continuing with your exercise program.
3. This equipment is intended for adult use only. Keep children and pets away from the machine. DO NOT leave children unattended in the same room with the equipment.
4. Use the equipment on a solid, flat level surface with a protective cover for your floor or carpet. To ensure safety, the equipment should have at least 2 feet of free space all around it.
5. Check if you have all the components and tools listed. Please note that some components are pre-assembled to help make the assembly process quick and easy.
6. Always use the equipment as intended. If you find any defective components while assembling or checking the equipment, or if you hear any unusual noises coming from the equipment during exercise, discontinue use immediately and do not use until the problem has been rectified.
7. Always wear appropriate workout clothing when exercising. Do not wear clothing that can get tangled in the equipment.
8. Keep hands and other objects away from all moving parts.
9. The maximum user's weight is 300 lbs / 135kgs.
10. Be careful when lifting and moving the equipment. Always use proper lifting technique and seek assistance if necessary.
11. Your equipment is intended for use in cool, dry conditions. You should avoid storage in extreme cold, hot, or damp areas as this may lead to corrosion and other related problems.
12. This equipment is designed and intended for indoor use only, not for commercial use.

SAVE THESE INSTRUCTIONS

 **WARNING:** This product can expose you to one or more chemicals known to the State of California to cause cancer and birth defects or reproduction harm. For more information go to www.P65Warnings.ca.gov.

EXPLODED DRAWING

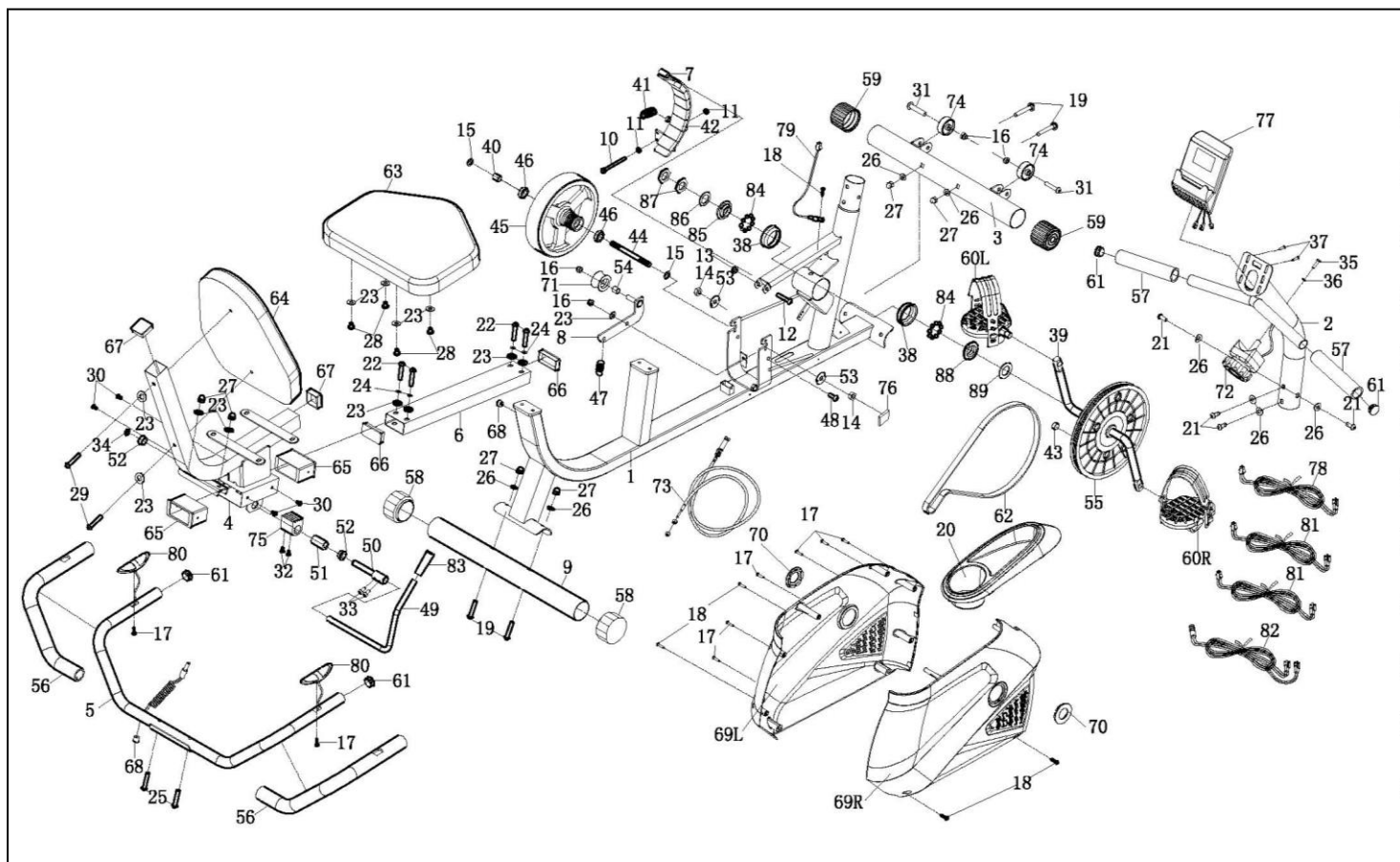

PARTS LIST

No.	Description	Qty.
1	Main Frame	1
2	Front Post	1
3	Front Stabilizer	1
4	Cushion Frame	1
5	Handlebar	1
6	Seat Adjusting Tube	1
7	Magnetic Board	1
8	Idler Link	1
9	Rear Stabilizer	1
10	Hex Tap Bolt M6*70	1
11	Hex Nut M6	2
12	Hex Tap Bolt M6*70	1
13	Plastic Nut M8 S13	1
14	Hex Thin Nut M10*1*H5	2
15	Taper Thin Nut M10*1*H4	2
16	Plastic Nut M8 S13	4
17	Screw ST4.2*20	8
18	Screw ST4.2*20	5
19	Carriage Bolt M8*60,8,20	4
20	Upper Cover	1
21	Bolt M8*20 Full Teeth S5	4
22	Bolt M8*45,20,S5	4
23	Flat Washer Ø8* Ø16*1.5	13
24	Spring Washer Ø8	4
25	Carriage Bolt M8*42	2
26	Arc Washer Ø8* Ø16*1.5	8
27	Cap Nut M8	6
28	Bolt M8*16,S5	4
29	Bolt M8*50,20,S5	2
30	Screw M5*8	4
31	Screw M8*38, 15-S5	2
32	Screw M5*15	2
33	Screw M6*15 S5	2
34	Lock Washer for Shaft D12	1
35	Bolt M5*45 Full Teeth	1
36	Arc Washer 20*6*1	1

No.	Description	Qty.
37	Bolt M5*10 Full Teeth	2
38	Bearing Housing Ø56*15.5	2
39	Crank 140*220 1/2	1
40	Flywheel Spacer 16*10.2*17	1
41	Tension Spring 18*48	1
42	Black Magnet 40*25*10	9
43	Round Magnet 15*6	1
44	Inertia Wheel 10*125*M10*1*17	1
45	External Magnetic Flywheel 200*72.5/3kg	1
46	Bearing 6000Z	2
47	Tension Spring 18*48	1
48	Tap Bolt 9.8*4*M8*15	1
49	Brake Handle 12*380	1
50	Eccentric Shaft 12*105	1
51	Eccentric Wheel 20*38	1
52	Bushing Set 23*12.2*11	2
53	Lock Washer 30*2	2
54	Idler Spacer 16*10.2*10	1
55	Pulley 240/J6	1
56	Foam Grip 3*33*450	2
57	Foam Grip 3*33*160	2
58	End Cap	2
59	End Cap	2
60L/R	Pedal	1
61	Round End Cap 25*1.5 Tube	4
62	Leather Belt 370 PJ6	1
63	Seat Cushion 360*280*40	1
64	Backrest Cushion 380*290*40	1
65	Sleeve 80*40*1.5 Tube	2
66	End Cap	2
67	End Cap	2
68	Plug	2
69L/R	Belt Cover	1
70	Crank Plug	2
71	Arc Idler Ø 43.5*25 included a 6000 Bearing	1
72	Tension Knob 280mm Wire	1

73	Tension Wire 760mm	1
74	Transportation Wheel 41*8.5*20	2
75	Brake Block 40*38*32	1
76	EV Pad 40*20*3	1
77	Computer	1
78	Trunk Line 1 600mm	1
79	Needle Sensor Line 500mm with Seat	1
80	Hand Pulse Sensor 700mm	2
81	Hand Pulse Wire 1 600mm	2
82	Hand Pulse Wire 2 1600mm	1

83	Brake Handset 24*77*Hole 12	1
84	Bearing Ø46*8	2
85	Two Groove Nut Ø46*12 Teeth on Left	1
86	Locking Washer Ø46*2	1
87	Hex Nut 32*32*4	2
88	Three Slot Nut Ø46*12	1
89	Washer Ø40.5*3	1
90	Spanner S=13 14 15 17 Ø5	1
91	Allen Wrench S5	1

HARDWARE PACKAGE

SF-RB034

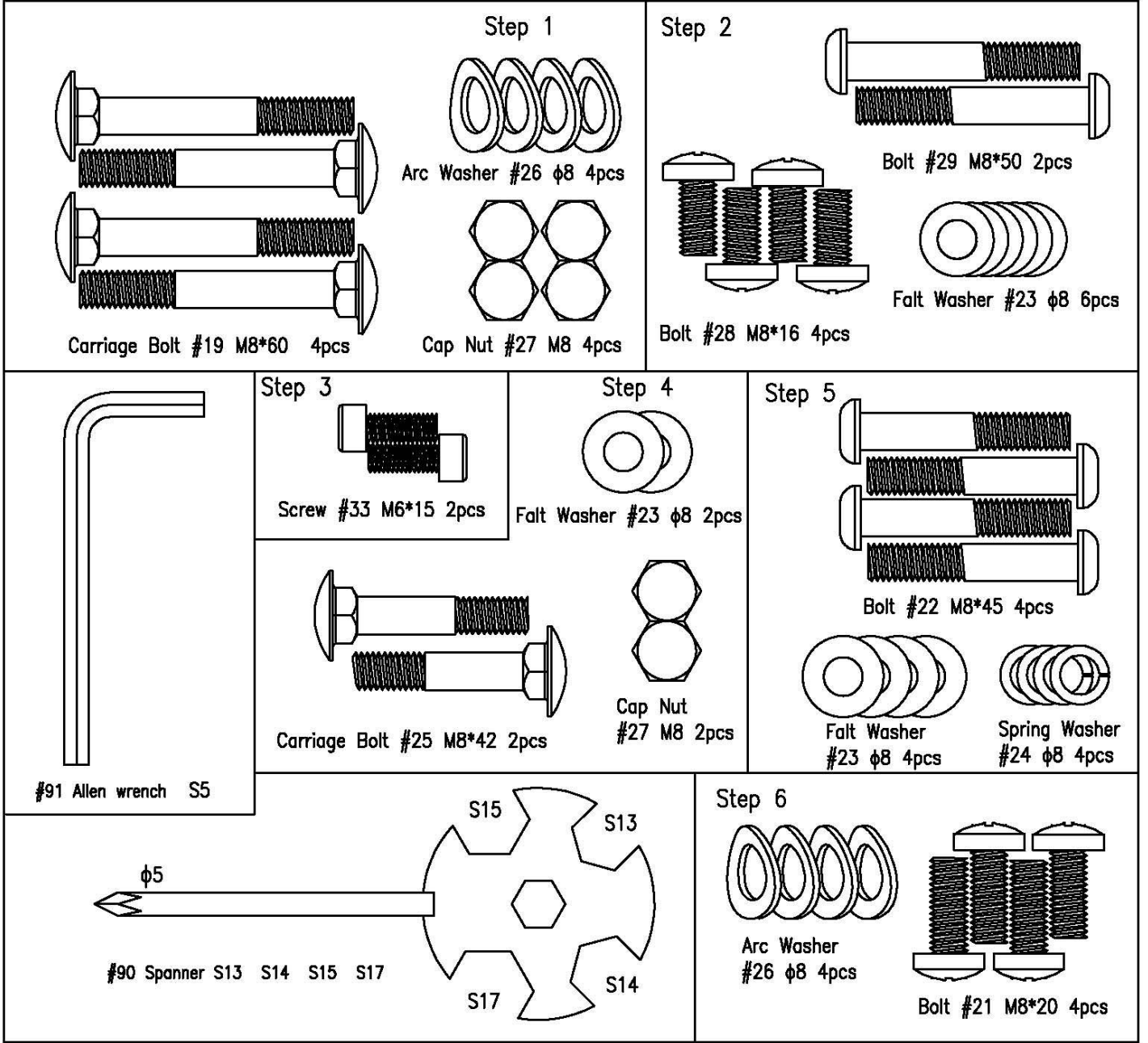

ASSEMBLY INSTRUCTIONS

Step 1:

Attach the **Front Stabilizer (No.3)** to the **Main Frame (No.1)** using 2 **Carriage Bolts (No.19)**, 2 **Arc Washers (No.26)** and 2 **Cap Nuts (No. 27)**. Tighten with **Spanner (No.90)**.

Attach the **Rear Stabilizer (No.9)** to the **Main Frame (No.1)** using 2 **Carriage Bolts (No.19)**, 2 **Arc Washers (No.26)** and 2 **Cap Nuts (No. 27)**. Tighten with **Spanner (No.90)**.

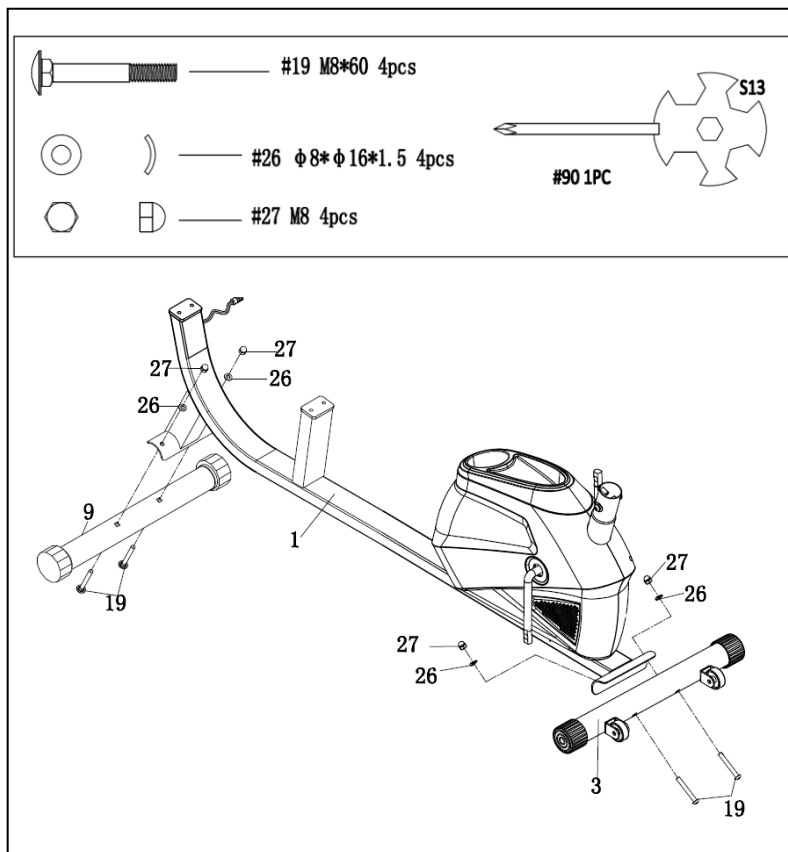

Step 2:

Attach the **Seat Cushion (No.63)** to the **Cushion Frame (No.4)**, making sure the correct side is facing up, using 4 **Bolts (No.28)** and 4 **Flat Washers (No.23)**. Tighten with **Allen Wrench (No.91)**.

Attach the **Backrest Cushion (No.64)** to the **Cushion Frame (No.4)** using 2 **Bolts (No.29)** and 2 **Flat Washers (No.23)**. Tighten with **Allen Wrench (No.91)**.

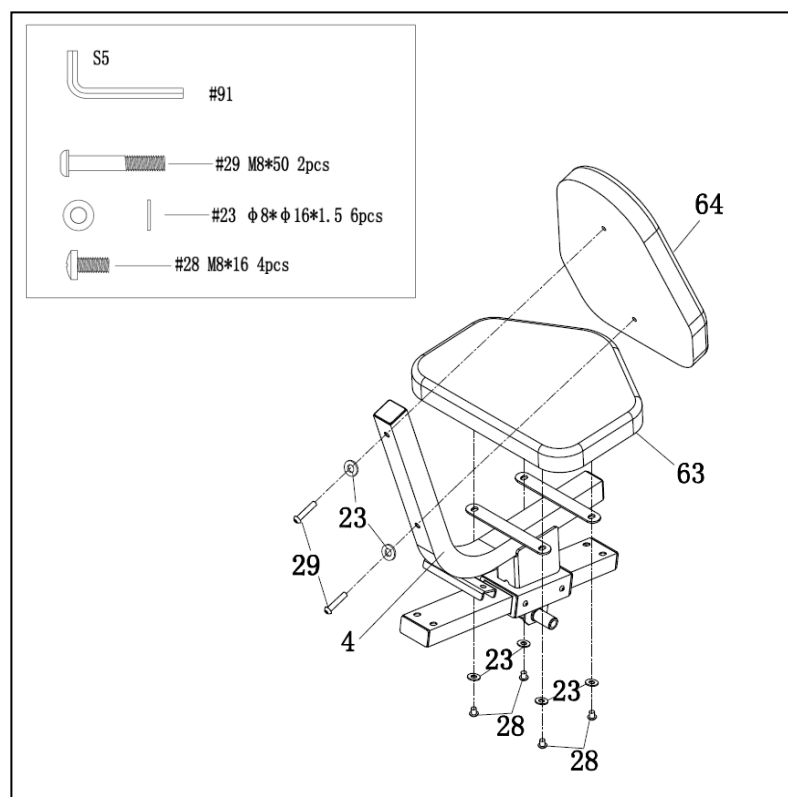

Step 3:

Insert the **Brake Handle (No.49)** into the hole of **Eccentric Shaft (No.50)**, making sure the correct side is facing up, and then lock with 2 **Screws (No.33)**. Tighten with **Allen Wrench (No.91)**.

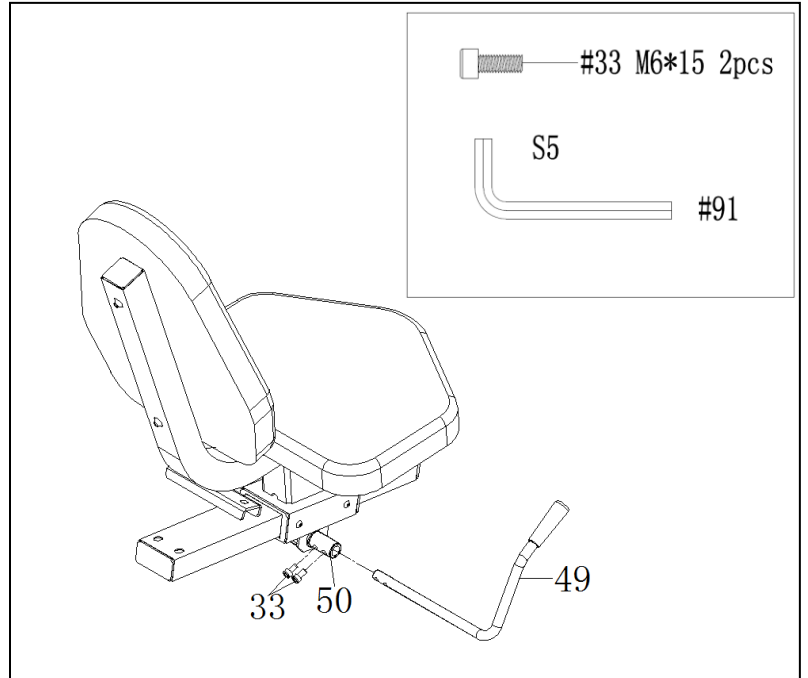

Step 4:

Attach the **Handlebar (No.5)** to the **Cushion Frame (No.4)** using 2 **Carriage Bolts (No.25)**, 2 **Flat Washers (No.23)** and the 2 **Cap Nuts (No.27)**. Tighten with **Spanner (No.90)**.

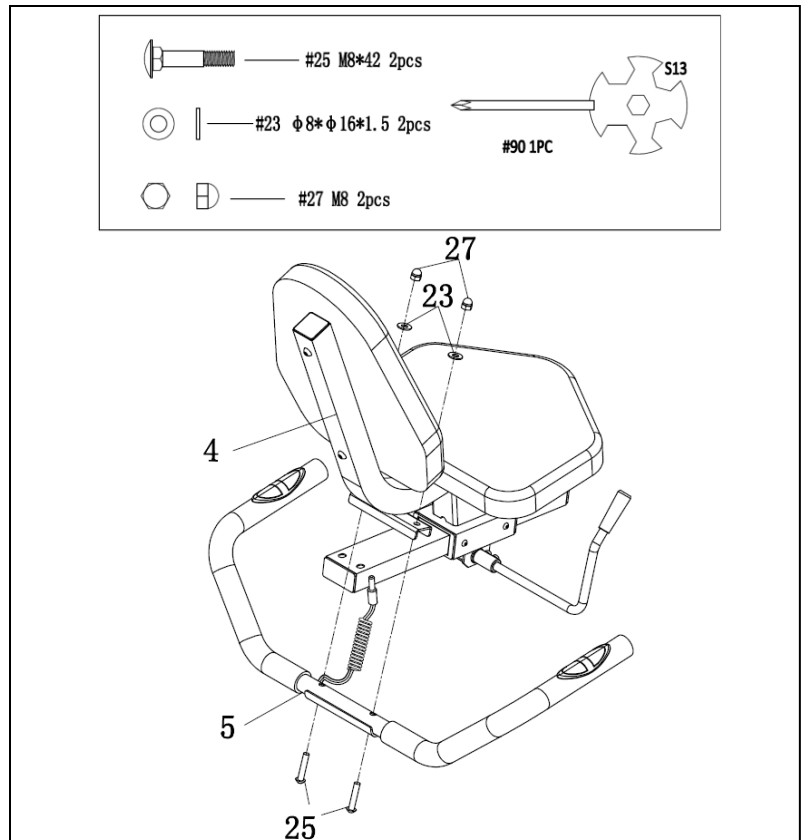

Step 5:

Attach the **Cushion Frame (No.4)** to the **Main Frame (No.1)** using 4 **Bolts (No.22)**, 4 **Spring Washers (No.24)**, and 4 **Flat Washers (No. 23)**. Tighten with **Allen Wrench (No.91)**. Then connect the **Hand Pulse Sensor (No.80)** with the **Hand Pulse Wire (No.81)**.

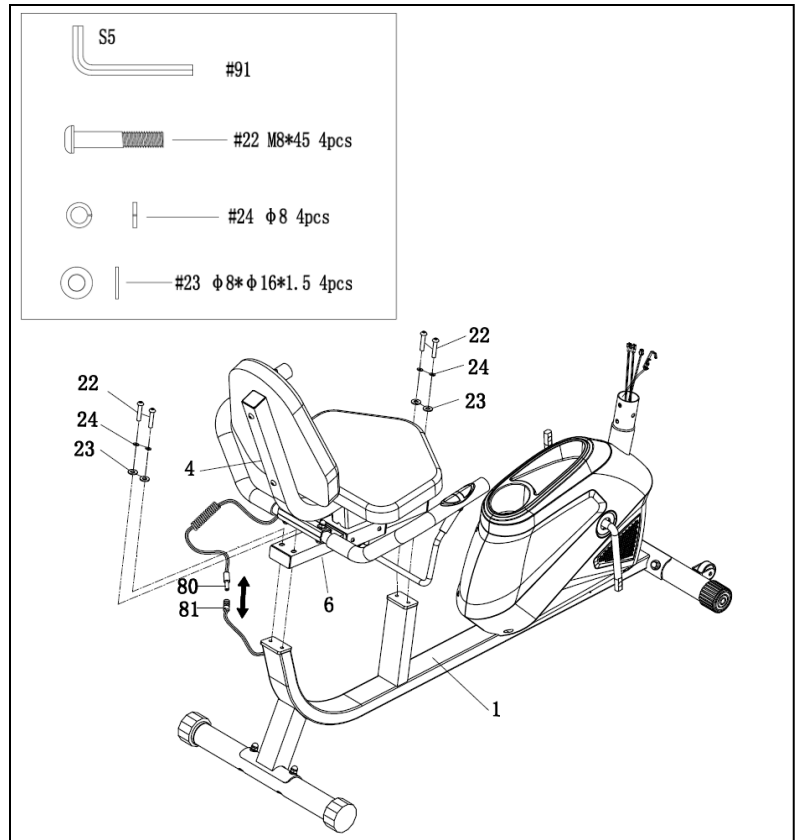

Step 6:

Set the **Tension Knob (No.72)** at level 1 to ensure the wire is at its longest length. Insert the wire of **Tension Knob (No.72)** to **Tension Wire (No.73)** as shown. Then connect the **Trunk Line (No.78)** with the **Needle Sensor Line (No.79)** and connect 2 **Hand Pulse Wires (No.81)** with 2 **Hand Pulse Wires (No.82)** as shown.

Attach the **Front Post (No.2)** to the **Main Frame (No.1)**, making sure align the screw holes, using 4 **Bolts (No.21)** and 4 **Arc Washers (No.26)**, tighten with **Allen Wrench (No.91)**.

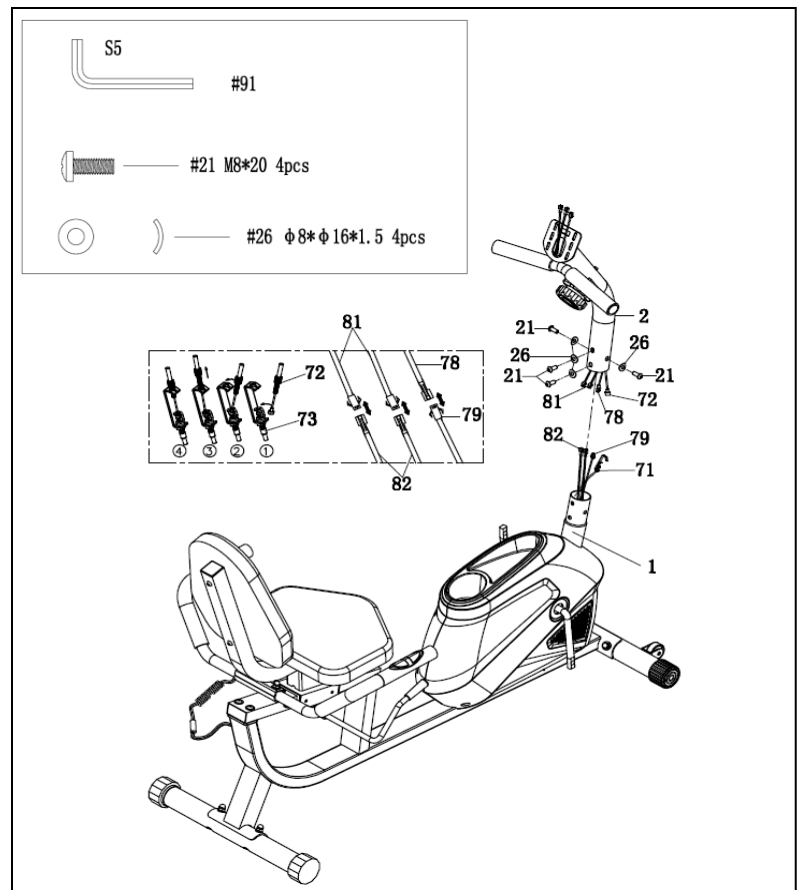

Step 7:

Connect 3 lines of **Computer (No.77)** with 2 **Hand Pulse Wires (No.82)** and **Trunk Line (No.78)** in turn. Then attach the **Computer (No.77)** to the **Front Post (No.2)** using 2 **Bolts (No.37)**. Tighten with **Spanner (No.90)**.

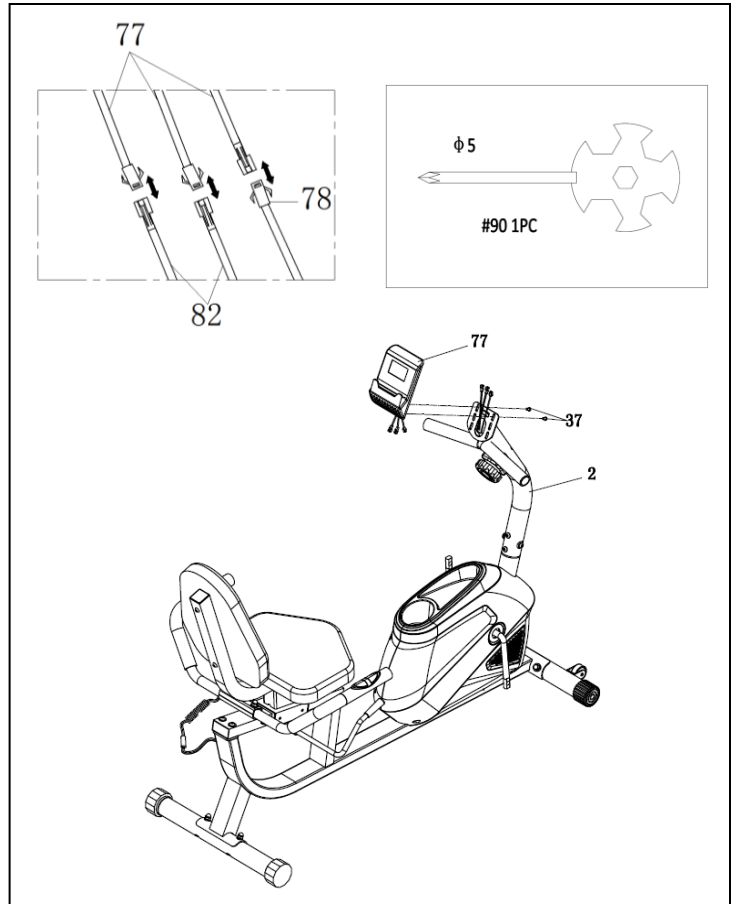

Step 8:

Connect the **Pedals (No.60L/R)** onto the **Crank (No.39)**.

Left Pedal: Align the **Left Pedal (No.60L)** with the **Left Crank Arm (No.39)** at 90 degrees and gently insert the pedal into the crank arm. Turn the pedal *counter-clockwise* as tightly as you can with your hand then secure with **Spanner (No.90)**.

Right Pedal: Align the **Right Pedal (No.60R)** with the **Right Crank Arm (No.39)** at 90 degrees and gently insert the pedal into the crank arm. Turn the pedal *clockwise* as tightly as you can with your hand then secure with **Spanner (No.90)**.

Assembly is complete!

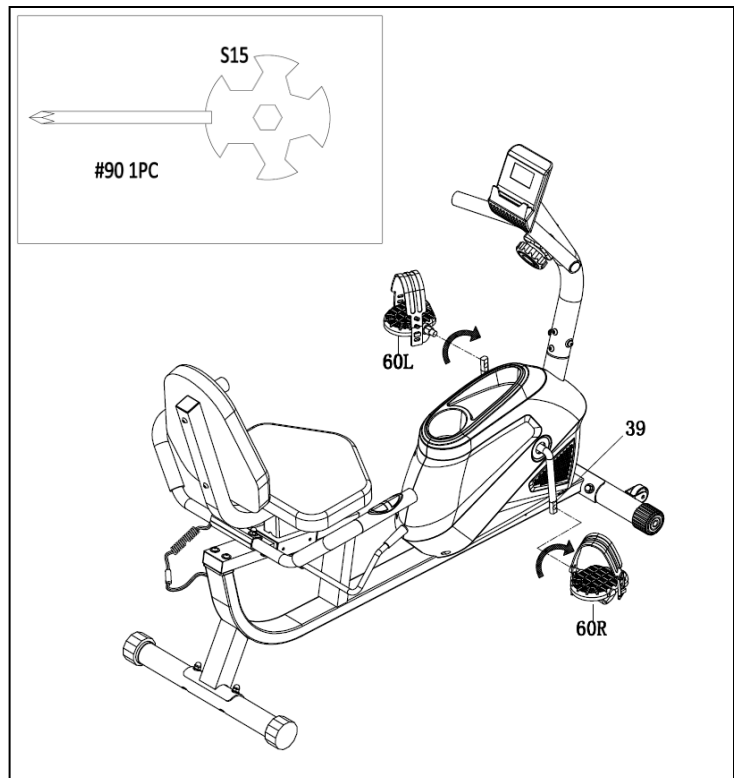

ADJUSTING THE SEAT

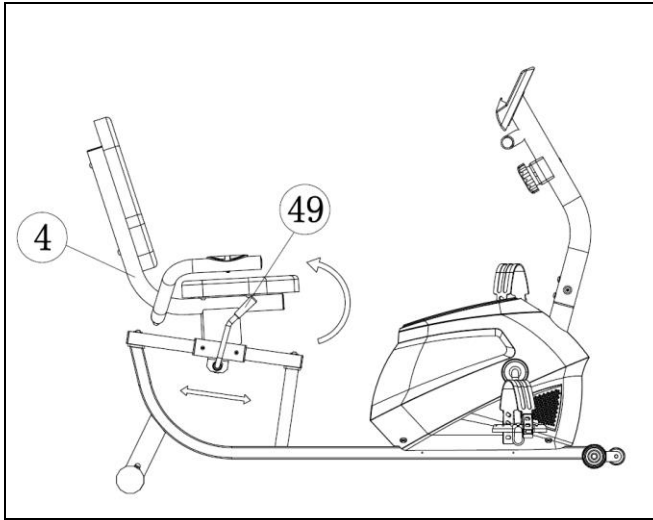

Fig. 1

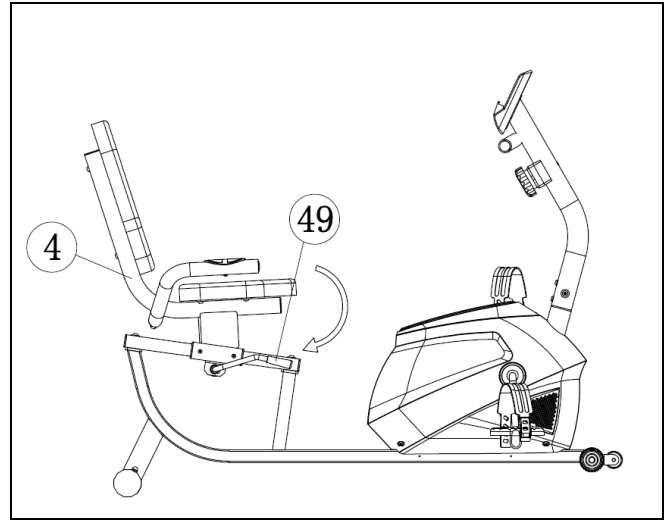
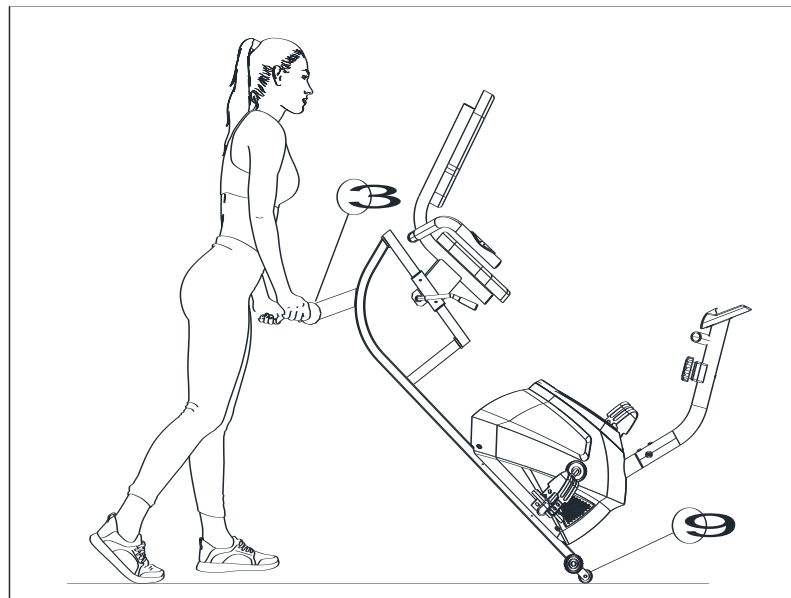

Fig. 2

Pull the **Brake Handle (No.49)** up to loosen (*Fig 1*). Keep your feet on the floor as leverage, then move the **Cushion Frame (No.4)** to the desired position. Push the **Brake Handle (No.49)** down to tighten (*Fig 2*).

HOW TO MOVE THE BIKE



Hold the **Rear Stabilizer (No.3)** and lift the bike until wheels on the **Front Stabilizer (No.9)** touch the ground. Now you can wheel the bike to the desired location.

ADJUSTING THE RESISTANCE

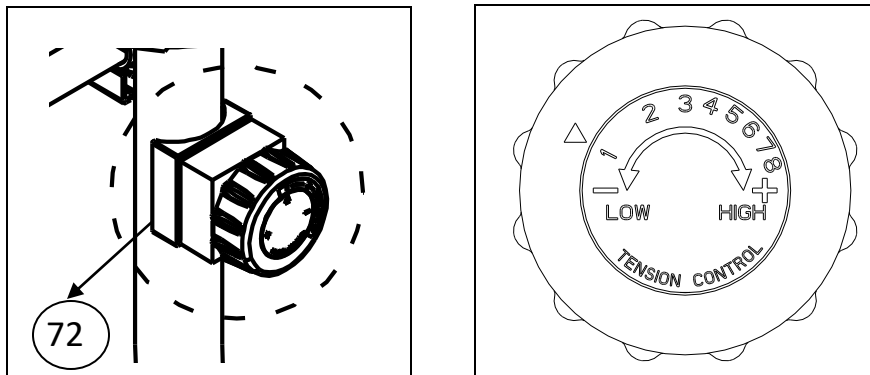

Adjust the resistance of the bike using the **Tension Knob (No.72)**. Increase the level of resistance by turning the tension knob to the **RIGHT (clockwise)**, decrease the level of resistance by turning the tension knob to the **LEFT (counter-clockwise)**.

ADJUSTING THE HEIGHT AND BALANCE

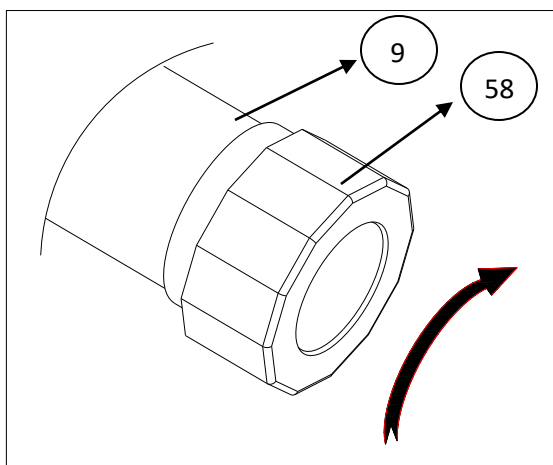

In order to achieve a smooth and comfortable ride, you must ensure that the bike is stable. If you notice that the bike is unbalanced during use, you should adjust the **End Caps (No.58)** located beneath the **Rear Stabilizer (No.9)**. To do so, turn it *clockwise*.

COMPUTER INSTRUCTIONS

FUNCTION BUTTONS:

MODE: Press to select functions.

SET: Press to set values of time, distance, calories, or pulse when not in SCAN mode.

RESET: Press to reset time, distance and calories to zero when not in SCAN mode.

Press and hold for a few seconds to reset all values.

AUTO ON/OFF

To turn on the meter, start pedaling or press any key.

After approximately 4 minutes of inactivity, the monitor will turn off.

This meter can (1) count the value from this workout (2) countdown from a value you set.

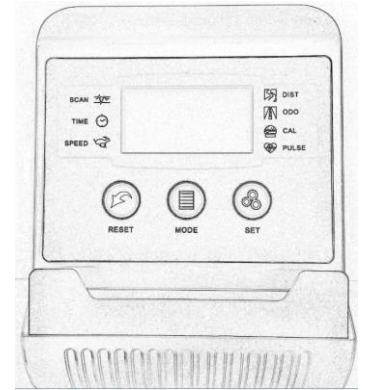

OPERATION PROCEDURES:

SCAN: Press MODE until pointer points to SCAN. Display will rotate through all 6 functions: Time, Speed, Distance, Calorie, ODO and Pulse. Pointer will point to the function being displayed. Each function will display for 4 seconds. If you want to view a specific function, press MODE until pointer points to function you want.

TIME: Displays time of your exercise session.

SPEED: Displays current speed.

DISTANCE: Displays distance you have pedaled.

CALORIES: Displays the approximate number of calories burned.

ODOMETER: Displays the total accumulated distance. Pressing RESET does not reset the odometer. Taking out the batteries resets the odometer.

PULSE: Press MODE until pointer points to PULSE. Before measuring your pulse rate, place the palms of your hands on both contact pads and the monitor will show your current heart beat rate in beats per minute (BPM) on the LCD after 6~7 seconds.

During the process of pulse measurement, the measurement value may be higher than the virtual pulse rate during the first 2~3 seconds, then will return to normal level. The measurement value cannot be regarded as the basis of medical treatment.

COUNTDOWN FUNCTION:

The meter has a countdown function for TIME, DISTANCE, and CALORIES. To use the countdown function, press MODE to select TIME, DISTANCE or CALORIES. Press SET to set the value. You can start pedaling. The meter will countdown from the value you set. When the countdown is done, it will automatically start counting from 0.

NOTE: If the display is faint or shows no figures, replace the batteries. When you replace batteries, replace both at the same time. Do not mix battery types. Do not mix old and new batteries. Dispose old batteries according to your state and regional guidelines.

SPECIFICATIONS:

FUNCTION	AUTO SCAN	Every 4 seconds
	TIME	00:00'~99:59'
	CURRENT SPEED	The maximum signal can be pickup is 99.9 MI/H
	TRIP DISTANCE	0.00~99.99 MI or 0.00~9999 MI
	CALORIES	0.1~999.9 KCAL
	ODO	0.1~999.9 MI or 1 ~ 9999 MI
	PULSE RATE	40~206 BPM
BATTERY TYPE		2pcs of SIZE –AAA or UM –4
OPERATING TEMPERATURE		0°C ~ +40°C (32°~104°F)
STORAGE TEMPERATURE		-10°C ~ +60°C (-14°~140°F)

V 1