

User's Guide

Emma

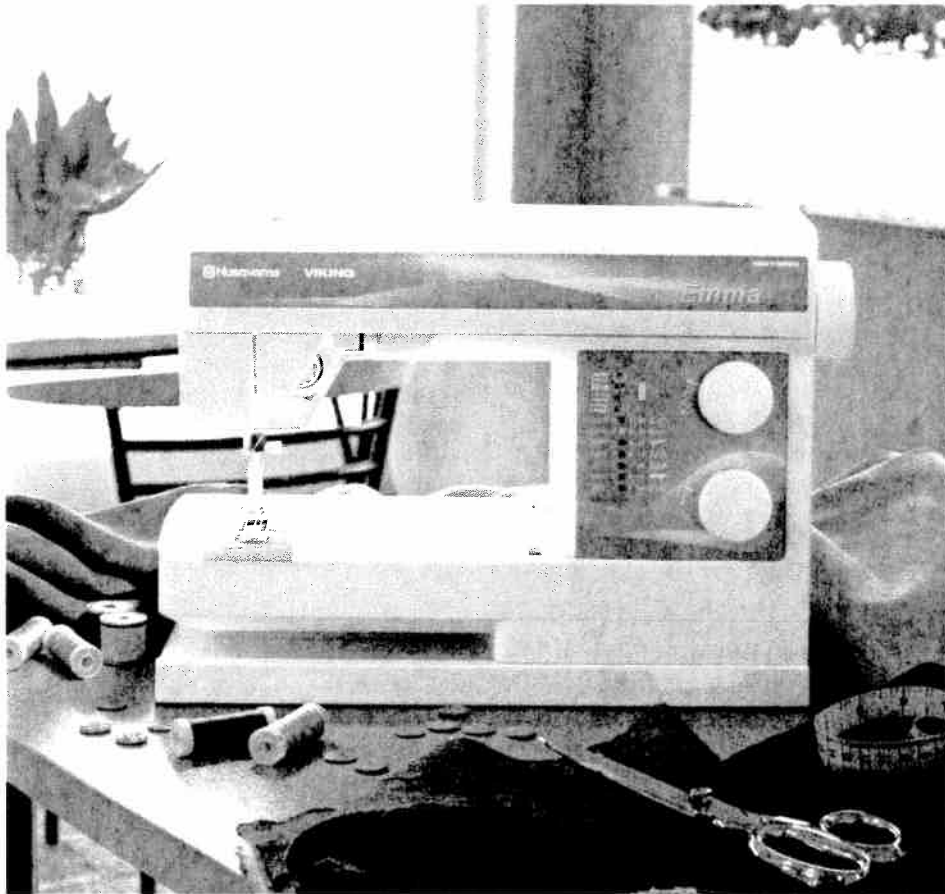

IMPORTANT SAFETY INSTRUCTIONS

When using an electrical appliance, basic safety precautions should always be followed, including the following:

Read all instructions before using this household sewing machine.

DANGER – To reduce the risk of electric shock:

- A sewing machine should never be left unattended when plugged in. Always unplug this sewing machine from the electric outlet immediately after using and before cleaning.
- Always unplug before relamping. Replace bulb with same type rated 15 Watts.

WARNING – To reduce the risk of burns, fire, electric shock, or injury to persons:

- Do not allow to be used as a toy. Close attention is necessary when this sewing machine is used by or near children.
- Use this sewing machine only for its intended use as described in this manual. Use only attachments recommended by the manufacturer as contained in this manual.
- Never operate this sewing machine if it has a damaged cord or plug, if it is not working properly, if it has been dropped or damaged, or dropped into water. Return the sewing machine to the nearest authorized dealer or service center for examination, repair, electrical or mechanical adjustment.
- Never operate the sewing machine with any air openings blocked. Keep ventilation openings of the sewing machine and foot controller free from the accumulation of lint, dust, and loose cloth.
- Keep fingers away from all moving parts. Special care is required around the sewing machine needle.
- Always use the proper needle plate. The wrong plate can cause the needle to break.
- Do not use bent needles.
- Do not pull or push fabric while stitching. It may deflect the needle causing it to break.
- Switch the sewing machine off ("0") when making any adjustments in the needle area, such as threading needle, changing needle, threading bobbin, or changing presser foot, etc.
- Always unplug sewing machine from electrical outlet when removing covers, lubrication, or when making any other user servicing adjustments mentioned in the instruction manual.
- Never drop or insert any object into any opening.
- Do not use outdoors.
- Do not operate where aerosol (spray) products are being used or where oxygen is being administered.
- To disconnect, turn all controls to the off ("0") position, then remove plug from outlet.
- Do not unplug by pulling on cord. To unplug, grasp the plug, not the cord.

SAVE THESE INSTRUCTIONS

Table of Contents

| | | | |
|--|-------------|--|--------------|
| Overview | 2 | Sewing | 14-23 |
| Procedures | 3-13 | Buttonholes | 14 |
| Unpacking, Packing Away After Sewing | 3 | Perfectly Balanced Buttonholes (PBB) | 15 |
| Connecting the Foot Control | 4 | Sewing Buttons, Cutting Buttonholes | 16 |
| Connecting to the Power Supply | 4 | Straight Stitch, Clearance Plate | 17 |
| Accessory Box, Extended Sewing Surface | 5 | Sewing Zippers, Lapped Zipper | 18 |
| Spool Pin | 6 | Reinforced Straight Stitch | 19 |
| Threading the Upper Thread | 7 | Needle Positions | 19 |
| Bobbin Winding with the Machine Threaded | 7 | Zigzag, Three-step Zigzag, Mending and Darning | 20 |
| Bobbin Winding – Vertical Spool Pin | 8 | Sewing Terry Cloth, Seam and overcast | 21 |
| Placing the Bobbin in the Machine | 8 | Blind Hem | 22 |
| Thread tension | 9 | Flatlock – Double Action Stitch | 23 |
| Changing the Needle, Changing the Presser Foot | 10 | Maintenance | 24-25 |
| Presser Foot Pressure, Presser Foot Lever | 10 | Trouble Shooting | 26-27 |
| Reverse, Lowering the Feed Teeth | 11 | | |
| Stitch Selection | 12 | | |
| Stitch Width, Stitch Length | 13 | | |

Overview

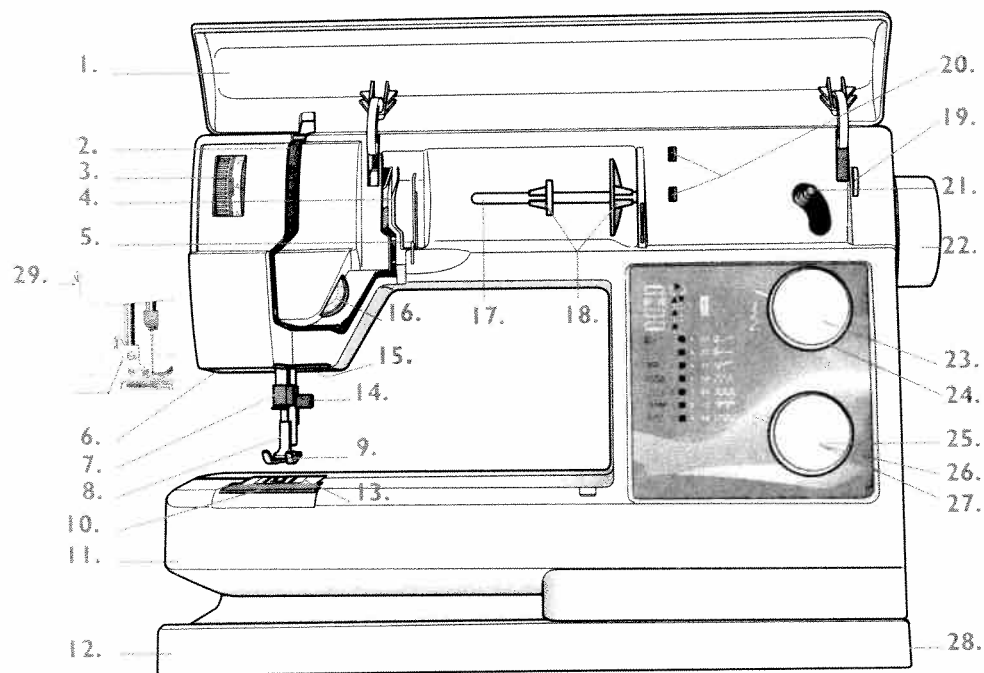

- | | |
|--|--|
| 1. Lid | 17. Spool pin |
| 2. Thread take-up lever | 18. Spool holders |
| 3. Presser foot pressure dial | 19. Thread cutter for bobbin winding |
| 4. Thread guide | 20. Recess for additional spool pin |
| 5. Thread guide for bobbin winding | 21. Bobbin spindle |
| 6. Light | 22. Handwheel |
| 7. Needle bar with needle clamp | 23. Stitch width dial |
| 8. Presser bar and Presser foot ankle | 24. Stitch selector |
| 9. Presser foot | 25. Stitch length dial |
| 10. Bobbin cover | 26. Reverse |
| 11. Free arm | 27. Drop feed teeth |
| 12. Base plate | 28. Main power switch, Connection to power supply |
| 13. Needle plate | 29. Thread cutter |
| 14. Needle clamp screw | |
| 15. Presser foot lever | |
| 16. Thread tension dial | |

Unpacking

1. Place the machine on the table or cabinet.
2. The foot control is stored at one of the side parts of the packing material. Press the foot control together and remove it.
3. The machine is delivered with an accessory bag and a foot control cord.
4. Wipe the machine, particularly around the needle and needle plate to remove any soil before sewing.
5. Remove the protection film from the stitch panel and the name plate.

Packing Away After Sewing

1. Unplug the cords from the wall socket and the machine.
2. Wind the cords around your hand and place the foot control cord in the foot control storage space.
3. Check to ensure that all accessories are in the accessory box. Slide it onto the machine behind the free arm.
4. Lower the presser foot.
5. Place the foot control, underside toward you, on the accessory box at the back of the machine.

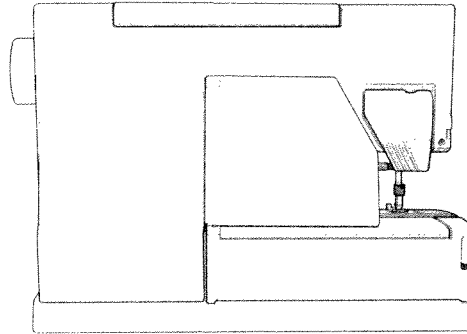

Connecting the Foot Control

Among the accessories you will find the foot control cord and the main cord.

1. Remove the foot control cord. Place the foot control on its narrow side. Fit the plug into the socket inside the foot control compartment.
2. Push it firmly to make sure it is properly connected. This operation is only necessary the very first time you are going to use the machine.
3. To correctly turn away the cord, place it into the slot.

Note: Before plugging in, check to ensure that the foot control is of type "FR2"/"FR4".

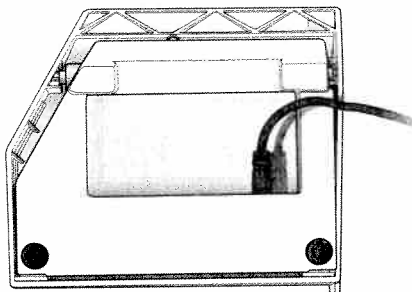
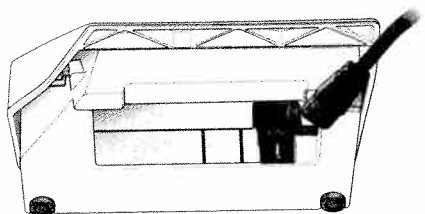

Connecting to the Power Supply

On the underside of the machine you will find information about the power supply (V) and the frequency (Hz). Check the power supply setting in the machine to ensure that this agrees with the main supply before you connect the machine.

1. Connect the foot control cord to the first socket on the bottom right side of the machine.
2. Connect the main cord to the back socket on the bottom right side of the machine.
3. When you press the power switch, both the machine and the light are switched on.

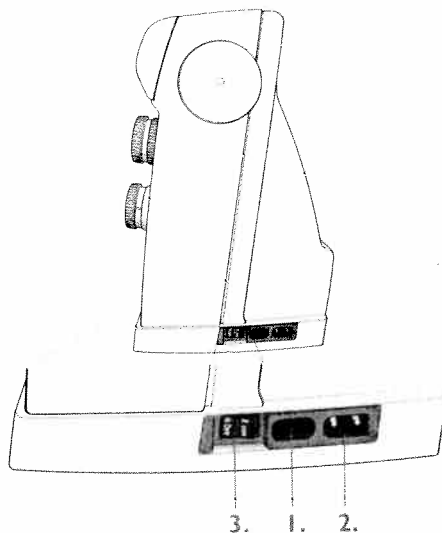

For the USA and Canada

This Sewing Machine has a polarized plug (one blade wider than the other). To reduce the risk of electric shock, this plug is intended to fit in a polarized outlet only one way. If the plug does not fit fully in the outlet, reverse the plug. If it still does not fit, contact a qualified electrician to install the proper outlet. Do not modify the plug in any way.

Accessory Box

1. Open the accessory box by placing your finger in the space on the top and lift upward.
2. Store the presser feet and the bobbins in the box from the beginning so they are always easily accessible.

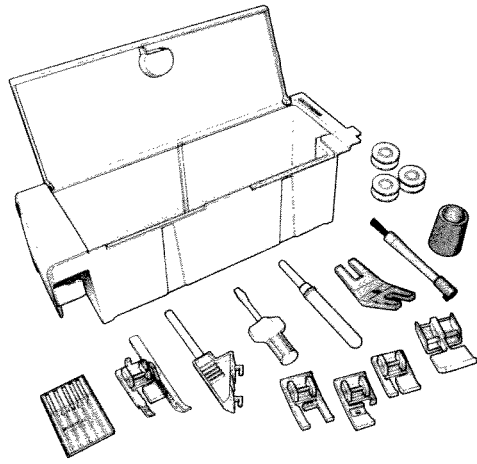

Extended Sewing Surface

1. Slide the accessory box onto the machine to provide a larger flat work surface.
2. Slide the accessory box to the left when you wish to remove it and use the free arm.
3. To facilitate sewing trouser legs and sleeve hems use the free arm. The free arm also allows you to darn socks (darning foot is an accessory).
4. To replace the accessory box, slide it tight onto the machine.

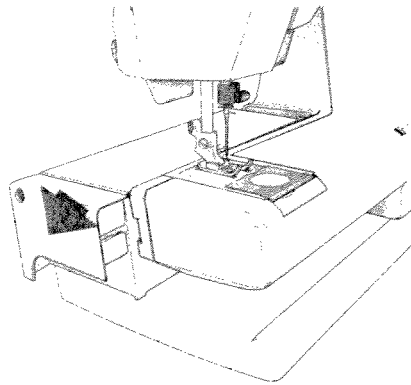

An extension table is also available as an accessory to provide an even larger sewing surface.

Spool Pin

The machine has spool pins suitable for all types of thread. The main spool pin (a) is adjustable – the thread reels off the stationary spool. Place the spool so that the thread reels counter-clockwise.

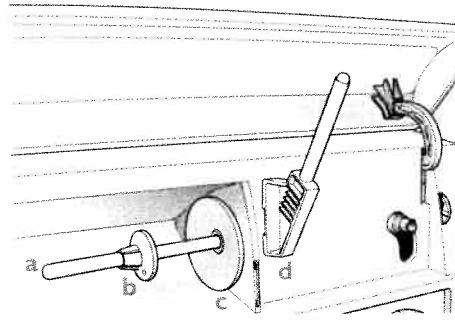

There are two spool holders on the spool pin. With narrow thread spools, the small holder (b) is placed in front of the thread. If you use large thread spools, the large holder (c) is placed in front of the thread.

Slide the correct size spool holder in place so the flat side is pressed firmly against the spool. No space between spool holder and spool.

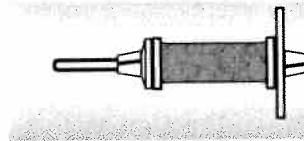

Narrow thread spool

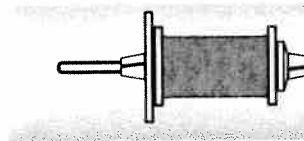

Large thread spool

There is also a separate spool pin (d) to be attached onto the machine. The fingers on the extra spool pin fit into the two holes to the right of the fixed spool pin. Push downward to snap in place.

The large spool holder (c) is placed under the thread. This spool pin is used when winding a bobbin from a second spool of thread or for a second spool when sewing with a twin needle.

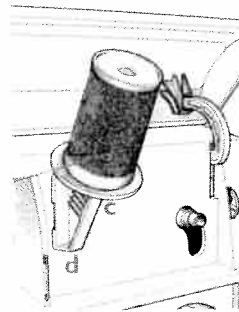

Threading the Upper Thread

Make sure the presser foot is raised and the needle is in the up position

1. Pull the spool pin out. Place the thread on the spool pin and the spool holder on the spool pin as described. Push the spool pin back in.
2. Bring the thread in the direction of the arrow under the thread guide (a) and over the thread guide (b).
3. Bring the thread down between the thread tension discs.
4. Continue threading by drawing the thread from the right into the slot on the take-up lever.
5. Thread last guide just above the needle.
6. The needle is threaded from front to back. The white on the presser foot ankle makes it easy to see the eye of the needle.
7. Place thread under the presser foot and into the thread knife where it is cut.

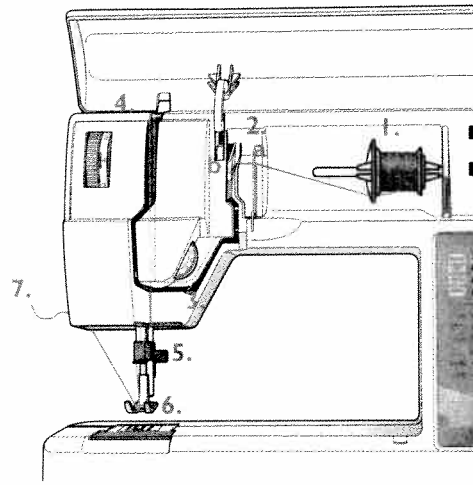

Bobbin Winding with the Machine Threaded

Make sure that the presser foot is up and the needle is in the highest position.

Note! Do not use a plastic presser foot when bobbin winding.

1. Place your empty bobbin with the small mark (H) outwards on the bobbin spindle on the front of the machine. Bring the bobbin spindle down.
2. Pull the thread from the needle under the presser foot and to the right over the thread guide (c).
3. Start from above and wind a few turns of thread around the bobbin. Cut off the thread on the thread knife (d).
4. Press the foot control. When the bobbin winding is finished, remove the bobbin, cut off the thread and bring the bobbin spindle up.

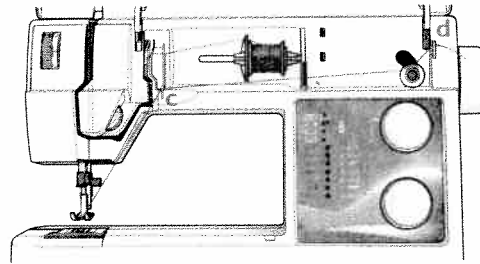

Note! We do not recommend winding specialty threads such as clear nylon or other stretchy threads through the needle. Instead see "Bobbin winding – vertical spool pin".

Bobbin Winding – Vertical Spool Pin

1. Place an empty bobbin with the mark  out-wards on the bobbin spindle and bring it down.
2. Place the large spool holder under the thread on the spool pin.
3. Bring the thread under the thread guide (a) and over thread guide (b), further under thread guide (c).
4. From above wind a few turns of thread around the bobbin and into the knife.
5. Press the foot control. When the bobbin winding is finished, remove the bobbin, cut off the thread and bring the bobbin spindle up.

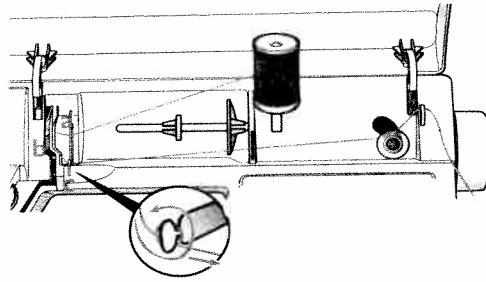

Placing the Bobbin in the Machine

1. Remove the bobbin cover by sliding it towards you.
2. Place the bobbin in the bobbin case with the mark  facing up and the thread to the left of the bobbin. The bobbin will then rotate counter clockwise while pulling out the thread.
3. Place your finger on the bobbin to keep it from turning as you pull the thread firmly to the right and then to the left into the tension spring (a) until it “clicks” into place.
4. Continue threading around (b) and to the right of and then left into the thread cutter (c). Replace the cover (1). Pull the thread to the left to cut it (2).

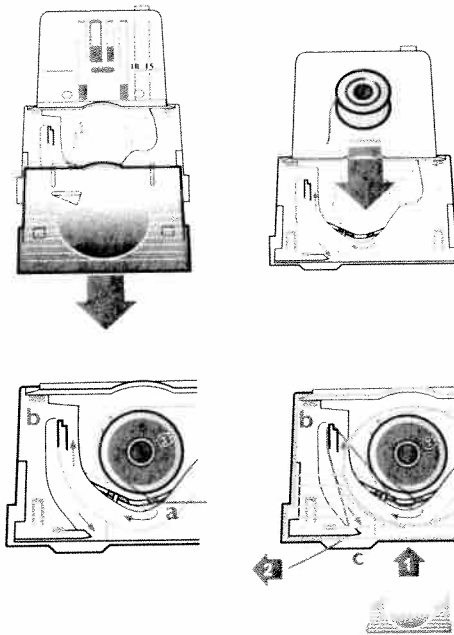

Thread tension

You can adjust the thread tension by turning the dial which is numbered. The higher the number the tighter the tension. Normal thread tension is number 4.

When sewing buttonholes and decorative stitches set thread tension to number 3.

When topstitching with a coarse thread in thick fabric, increase the tension to 7-9.

Correct and Incorrect Thread Tension

To understand the correct thread tension, sew a few sample stitches at different settings.

1. Begin with a tension that is too loose, i.e. set at "1". The lower thread will lie straight and the upper thread will be drawn down on the underside.
2. If you set the tension at the highest number, the opposite will occur, and the seam may pucker.
3. The correct thread tension is provided when the threads interlock in the middle of both layers of material or, in the case of decorative stitches, on the underside.

Make a few tests on a scrap piece of the material you are going to sew and check the tension.

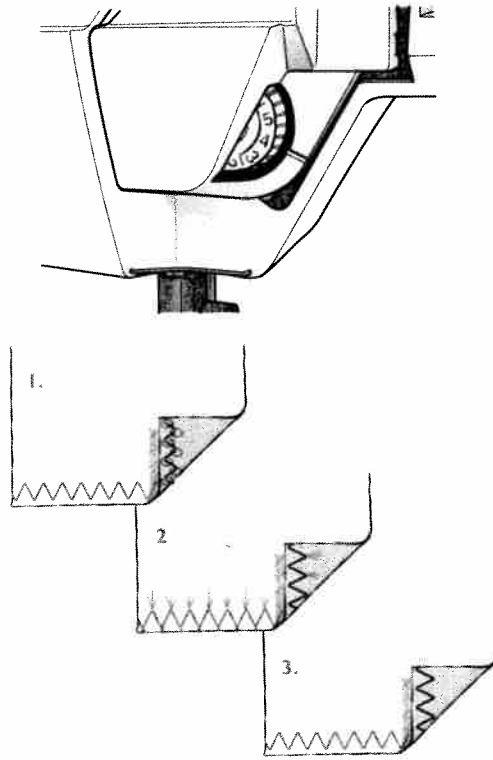

Changing the Needle

1. Loosen the screw in the needle clamp with the screwdriver.
2. Remove the needle.
3. Push up the new needle with the flat side away from you until it will go no further.
4. Use the screwdriver to tighten the screw properly.

Always use needles of system 130/705H.

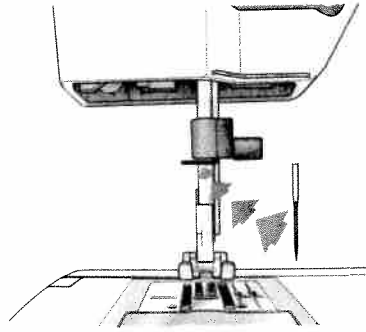

Changing the Presser Foot

1. Make sure that the needle is in the highest position. Pull the presser foot towards you.
2. Line up the cross pin on the foot between the spring and the presser foot ankle. Press back until the foot snaps into place.

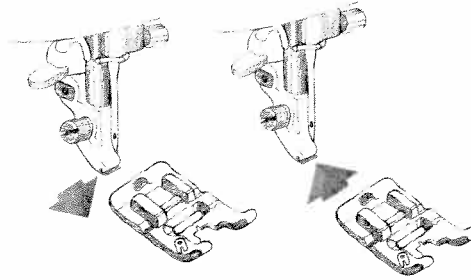

Presser Foot Pressure

The presser foot pressure is adjusted with the dial on the front of the machine. Normal setting is 4. The higher the number the more pressure on the fabric. Knit and Soft fabrics should be sewn at low pressure.

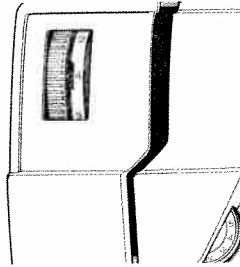

Presser Foot Lever

The presser foot is raised and lowered with the presser foot lever. The presser foot must be lowered when sewing.

By raising the presser foot lever as far as it goes and holding it there, the lift height of the presser foot can be increased by several millimeters. This is useful when sewing heavy materials.

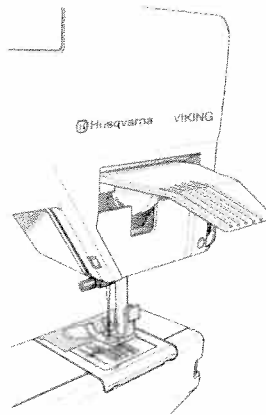

Reverse

Your machine sews backwards when the stitch length dial is pressed. The machine sews forward when the button is released.

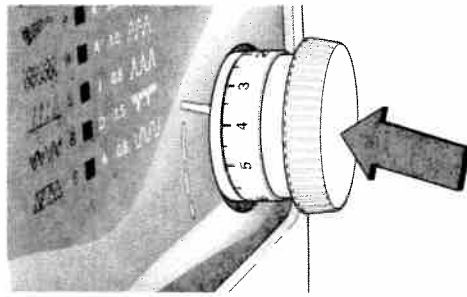

For permanent reverse, turn the stitch length dial to position .

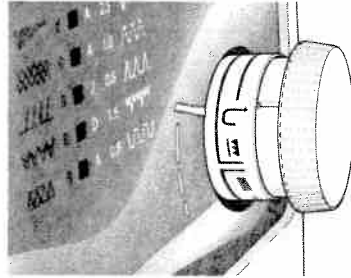

Lowering the Feed Teeth

The feed teeth are lowered when you turn the stitch length dial to . Turn the dial to the left if you wish to raise the feed teeth. The feed teeth will not come up until you begin to sew.

The feed teeth are lowered when sewing buttons and for free-hand work.

By lowering the feed teeth it is easier to get thick garments under the presser foot. Do not forget to raise the feed teeth before starting to sew.

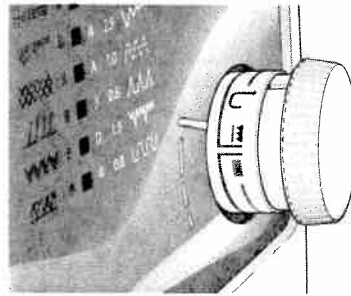

Stitch Selection

Your machine will sew all the stitches pictured on the front. The stitch is set by turning the stitch selector – the upper dial. A colored marker lines up while turning the stitch selector, showing which stitch is set.

Check that the needle is in its highest position before you turn the stitch selector.

The lower dial is to adjust the stitch length. The stitches are divided into two groups. Forward motion and trimotion stitches. The stitch length for the left group, forward motion stitches, can be varied between 0 and 6 and the width between 0-5.5.

Recommendations for the suggested stitch length are given next to the stitches.

When you wish to use one of the stitches in the right group, the trimotion stitches, you turn the stitch length dial to the left until it reaches the area . The stitch length is set for these stitches. The stitch width can be set between 0-5.5.

There are letters between the stitch pictures which indicate the most suitable presser foot for each stitch. The letter is also marked on the presser foot.

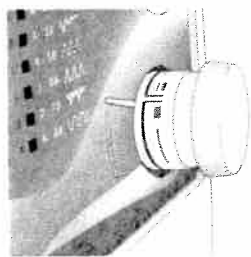
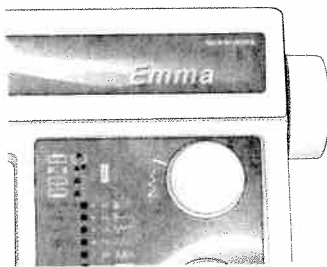

Stitch Width

When you select a stitch the machine automatically sets the best stitch width. By turning the stitch width dial (placed inside the stitch selector) you can change the stitch width. The width is numbered 0-5.5.

By setting the stitch width dial at 2.5 you can halve the width of the stitches. Most of the stitches will then get a different look and you have a selection of "new" stitches.

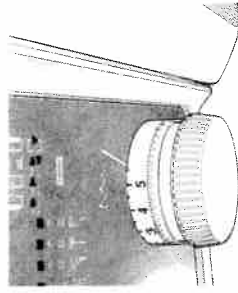

Stitch Length

Recommendations for the suitable setting are given next to the forward motion stitches.

Always use the recommended setting to start with but experiment until you arrive at the exact setting for the actual work you will be doing.

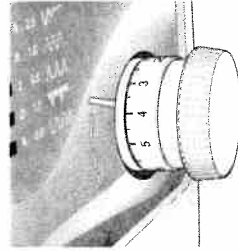

Buttonholes

To sew buttonholes we recommend the buttonhole foot. The buttonhole foot has a slide that is adjustable for different sizes of buttons. Put the button on the foot and push the slide together as far as it will go. The machine sews the first column in reverse. Stop the machine when the red mark on the slide has reached the beginning of the stitching.

Use the markings on the left toe of the buttonhole foot to position the garment edge. Place the edge of the garment at the middle mark to have $\frac{5}{8}$ " (15 mm) from the edge to the buttonhole.

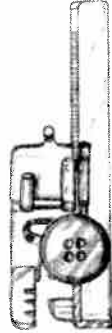
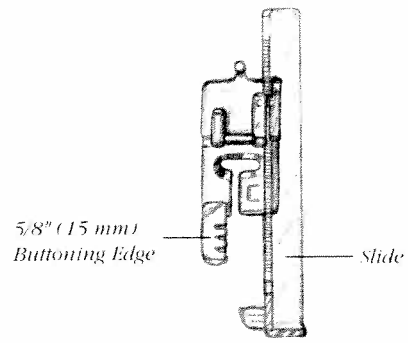

When sewing buttonholes in stretch fabrics we recommend cording the buttonhole to increase the stability and to keep the buttonhole from stretching out. For a corded buttonhole loop a piece of heavy thread around the finger at the back of the buttonhole foot as illustrated.

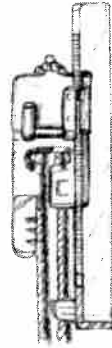



Perfectly Balanced Buttonholes (PBB)

Your Emma has the Perfect Balanced Buttonhole (PBB). The machine sews buttonholes with both columns stitched in the same direction to get a perfect result.

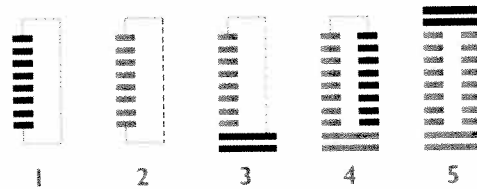
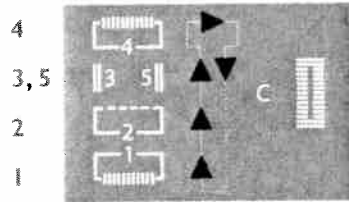
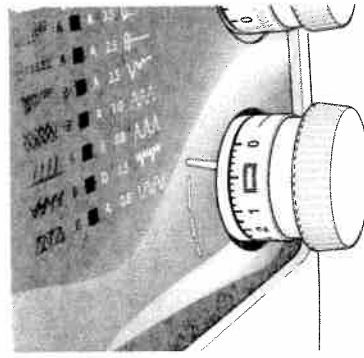
1. Set the stitch length dial to buttonhole symbol. Set the stitch selector to buttonhole (C), position 1. The size of the buttonhole is automatically determined by placing the button in the special buttonhole foot. The machine sews the first column in reverse. Sew until the left column of the buttonhole reaches the red mark on your buttonhole foot.
2. Turn the stitch width dial to set the stitch selector in position 2. Now the machine will sew a straight stitch towards you indicating the right column of your buttonhole. Sew the straight until you have reached the same length as the first column.
3. Set the stitch selector in position 3. Now the machine will stitch a bartack. Sew three or four stitches.
4. Turn the dial to position 4. The machine will stitch the second column of the buttonhole in reverse. Sew until you have reached the same length as the first column.
5. Now turn the dial to position 5 and stitch the final bartack. Sew three or four stitches. Turn the stitch width dial to 0 and lock the threads with a few stitches.



Sewing Buttons

1. Mark the fabric where the button is to be located.
2. Turn the stitch selector to zigzag .
3. Lower the feed teeth . See page 11.
4. Snap off the presser foot.
5. Place the material under the presser foot ankle.
6. Place the button on marking and lower the presser bar so that the presser foot ankle is between the holes of the button (see picture).
7. Hold the thread ends to one side. Turn the handwheel and check to be sure that the needle goes into the holes of the button.
8. Sew 5-6 stitches. Set the stitch width dial to 0 and lock the threads with a few stitches.

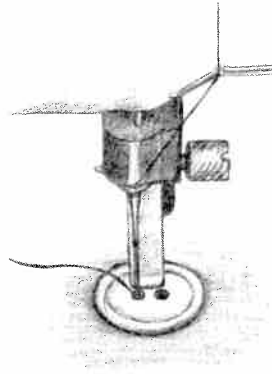

Use the clearance plate for this purpose. Use the thin end when sewing buttons on light fabrics, the thick end for heavier fabrics.

Push in the plate between the button and the fabric. Lower the presser bar and sew on the button. Pull the threads between the button and the fabric. Wind the threads a few times around the shank and tie the ends.

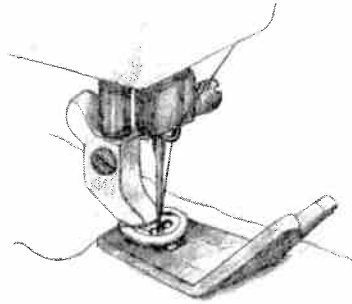

Cutting Buttonholes

Cut buttonhole open with the seam ripper. Place a straight pin across the end you are cutting toward to avoid cutting too far!

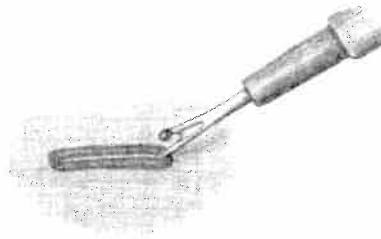

Straight Stitch

Straight stitching  is used to join fabric which does not stretch and for seams which will not be subjected to great strain.

Turn the stitch length dial to the recommended setting 2.5 to start with but experiment until you arrive at the exact setting for the actual work you will be doing.

Note: Increase the stitch length when basting and when topstitching.

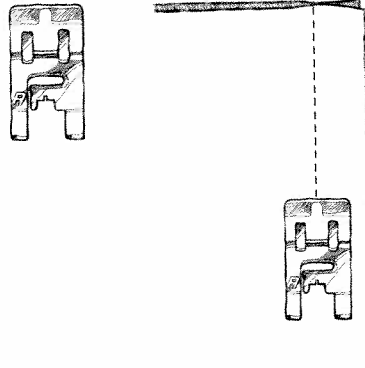

Clearance Plate

The clearance plate is used when sewing over thick seams.

One side of the plate is thicker than the other. Use the side that suits the thickness of the seam best.

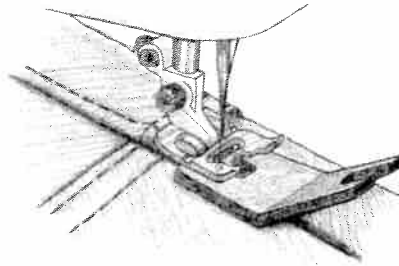
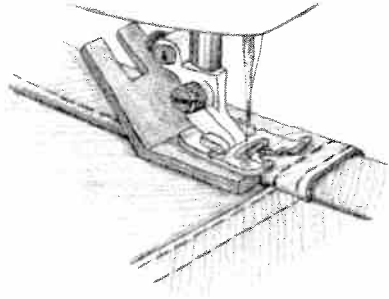

Sewing Zippers

The zipper foot E can be snapped on so that it is located either to the right or to the left of the needle, making it easy to sew both sides of the zipper. To sew the other side of the zipper, reposition the zipper foot.



Lapped Zipper



1. Sew the seam together to the bottom of the zipper placket. Baste the rest of the seam. Leave about 2 cm open at the top. Press seam open. **Set the needle to the right position.**
2. Place presser foot E to the left of the needle. From the wrong side fold the fabric to one side so both seam allowances are free. Fold and press the left allowance under approximately 0.5 cm from the basted seam.
3. Place the zipper under the folded seam allowance with the teeth as near to the fold as possible and stitch zipper to fabric close to fold. Begin sewing at the bottom of the zipper. Before reaching the zipper pull, lift the presser foot and slide the zipper pull down past the zipper foot. Lower the foot and sew to the top of the zipper.
4. Snap on the zipper foot so it is to the right of the needle. **Set the needle to the left position.** Turn the garment to the right side. It is important that the seam on the right side is sewn straight. Before you begin to sew, mark the seam line. Sew the other side of the zipper.

Begin stitching across the bottom and continue upwards. Remove the basting.

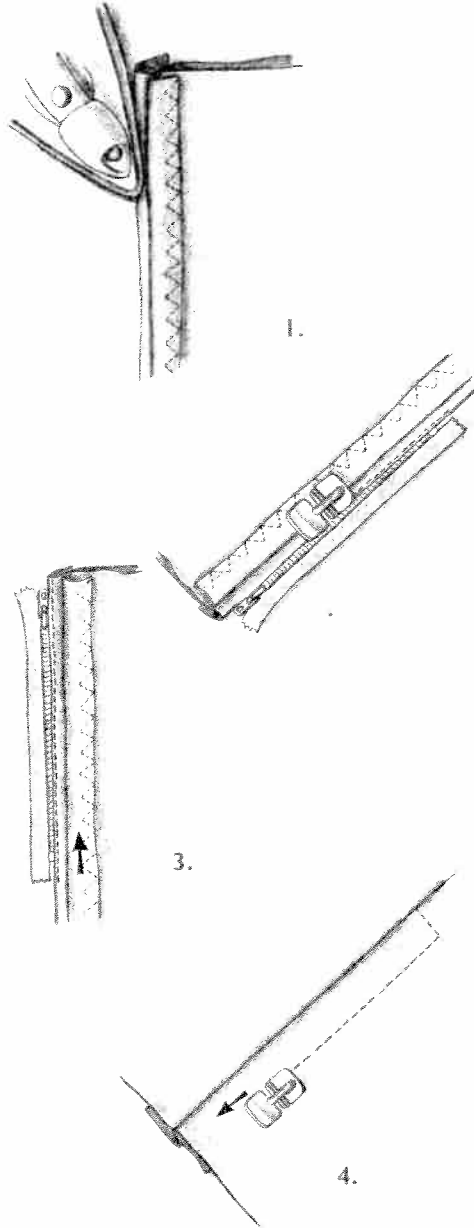
If you want to sew a "gentleman's zipper", follow the instructions but insert in the other direction.



Reinforced Straight Stitch

Turn the stitch length dial to the area  to sew reinforced straight stitch . This stitch is stronger than ordinary straight stitch, due to the fact that it is a triple and elastic stitch.

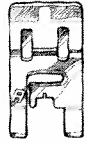

The reinforced straight stitch can be used for heavy stretch fabrics, for crotch seams which are subject to considerable strain and for topstitching in heavy fabrics.

Needle Positions

You can select straight stitch and reinforced straight stitch, with the needle in left position. The needle position can be adjusted in steps. Use the stitch width dial, turn to the right to reach the right position.

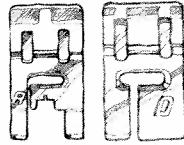

To edge stitch, you should take advantage of the possibility to set the needle to the left or the right position.

Fit presser foot A when sewing light fabrics and presser foot D for other fabrics.

Place the fabric and sew so that the edge follows the inside right edge of the presser foot D or the first mark of the left edge of the presser foot A.

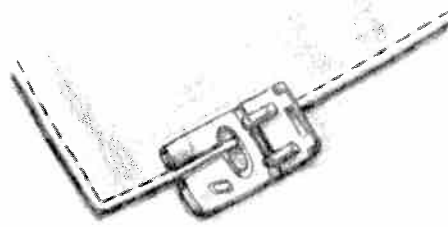

If you wish to sew about 5 mm from the edge or sew a narrow hem, use presser foot A and set the needle to the right position.

Place the edge of the fabric so that it follows the outside right edge of the presser foot and sew the hem.

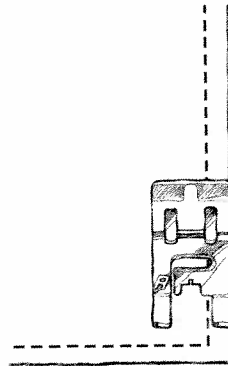

Zigzag

The zigzag  is utilized for sewing on lace, bound edging and appliques.

The zigzag width will be decreased from the left 5.5 mm width, steplessly to the right to 0 mm. In this position the machine sews straight stitch in the right needle position. Experiment until you reach the best setting for your actual work.

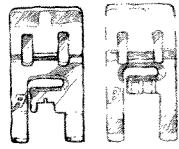

Three-step Zigzag

Overcasting

Three-step zigzag  is suitable for overcasting most fabrics. Trim the edges of the fabric before overcasting.

Make sure that the needle sews over the edge of the fabric. Place the fabric according to the presser foot (see picture).

Mending and Darning

Three-step zig-zag  can be utilized for mending and darning. A threadbare spot is mended by sewing back and forth with three-step zig-zag.

Use the reverse and for every row of stitching, guide the fabric slightly to the side. If the fabric is very worn, a piece of fabric or lining may be attached to the reverse side of the material as reinforcement.

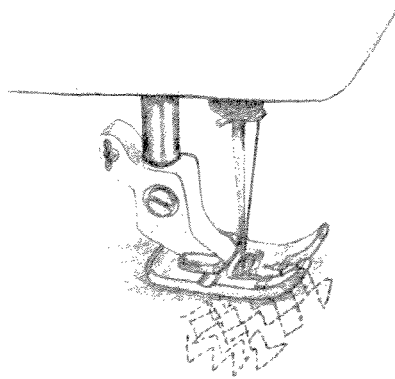

Sewing Terry Cloth

Terry cloth is a rather loosely woven fabric in which seams easily break.

Sew the garment together with straight stitch. Trim the seams and press the seam allowance flat and sew the edges down against the garment on the wrong side with three-step zigzag.

Even though the stitching goes right through to the "right" side of the garment, it is nearly invisible and even the wrong side looks neat.

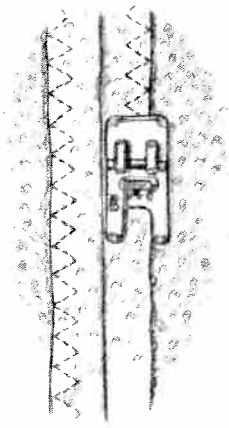

Seam and Overcast

Some stitches can be used for seaming and overcasting directly on the edge where a 5 mm (1/4") seam is allowed. Place the fabric so that the inside right "toe" of the presser foot follows the edge of the fabric.

Presser foot J is also used to overlock and overcast many different fabrics with the exception of heavy, firm fabrics. The pin on the presser foot should follow the edge of the fabric and will prevent the fabric from puckering. Stitch width 5.5 mm. Follow the recommended setting, given for stitch length.

Overcast stitch may be used to sew light and medium non-stretch fabric and light stretch fabric. Snap on presser foot J.

Overlock is chiefly used for sewing heavy stretch fabric. Snap on presser foot B.



Blind Hem

Presser foot D is used for blind hem .

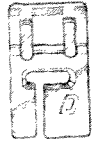

Fold the material as shown. Make sure that the fold line of the fabric rides in the groove under the right side of the presser foot.

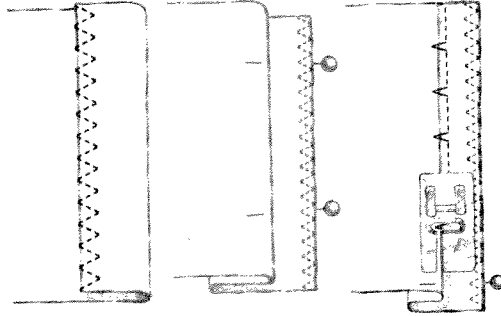

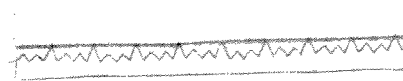
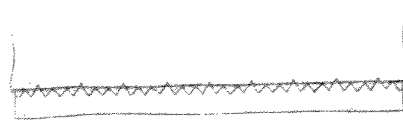
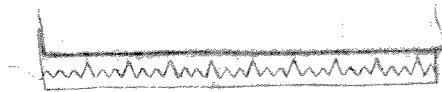

Practice using a scrap of material and compare with the illustrations.

1. If the stitch does not catch the folded edge, increase the stitch width.
2. If the stitch catches too much of the fold, decrease the stitch width.
3. For an invisible hem the needle catches a single thread of the folded edge.



Flatlock – Double Action Stitch

Flatlock or Double Action stitch  , is suitable for sewing overlapped seams and decorative hems.

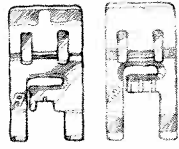

You can produce a decorative hem by folding a single hem to the wrong side and sewing the flatlock from the right side.

Trim excess hem to stitching from the wrong side.

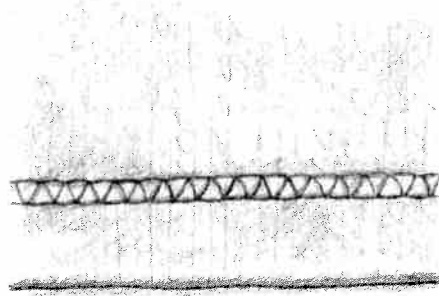

To sew an overlapped seam, lap one piece of fabric over the other piece and sew flatlock stitch over the fabric edge on the right side.

Trim from the wrong side or sew another seam from the right side.

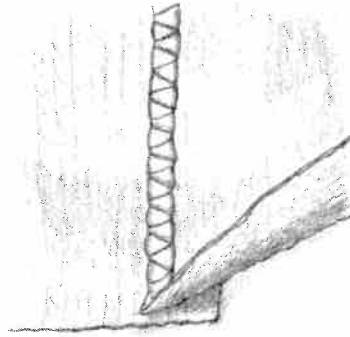

When gathering with narrow, flat elastic or elastic cord, use the double-action stitch. To be sure the elastic does not get stitched in but can run freely, use presser foot A or B and slip narrow elastic between the toes of the foot.

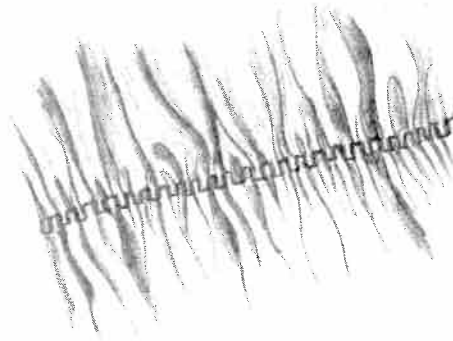

Maintenance

Changing the Light Bulb

1. The light bulb is placed to the left of the needle. Place the rubber sheath found in the accessory box around the bulb, turn a quarter of a turn in the direction of the arrow and remove the bulb.

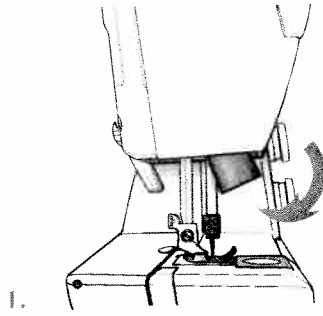

2. When inserting, place the rubber sheath around the new bulb, insert the bulb and turn a quarter of a turn in the direction of the arrow. Use light bulb designed as indicated on the front of the machine (15 W).

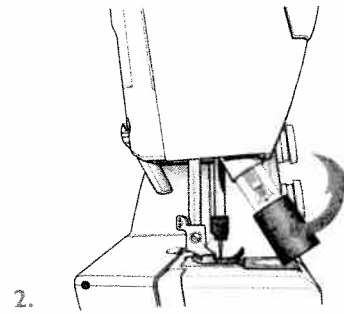

Care of the Machine

To keep your sewing machine operating satisfactorily, it requires, like other precision machines, regular cleaning. No lubrication (oiling) is needed.

Clean the Bobbin Area

Remove the presser foot and slide off the bobbin cover. Lower the feed teeth. Place the stitch plate opener on the brush, and then in the recess at the rear of the stitch plate. Turn toward you to pop off the stitch plate. Clean the feed teeth with the brush.

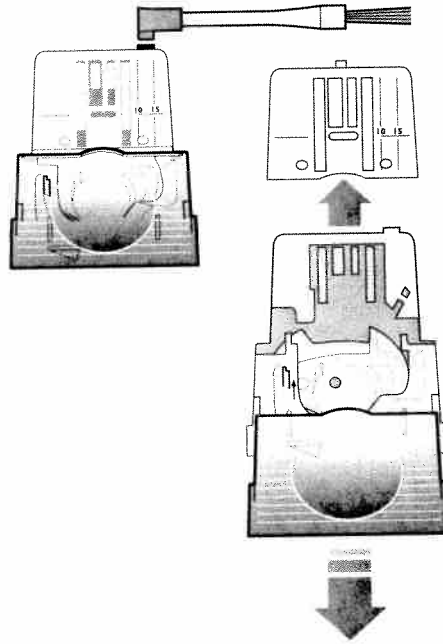

Cleaning Under the Bobbin Area

When lint builds up, the area under the bobbin case must be cleaned.

Remove the bobbin case holder (1) covering the front part of the bobbin case (2). Remove the bobbin case by lifting it up. Clean with the brush.

Replace the bobbin case and the bobbin case holder.

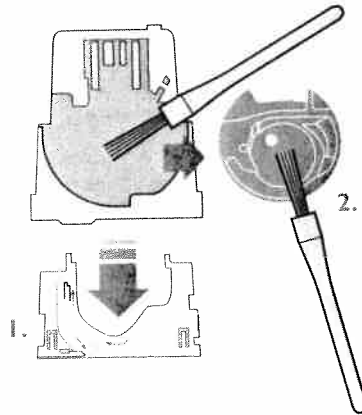

Replacing the Stitch Plate

With feed teeth down, place the stitch plate about 5 mm in front of the rear edge and push it back. Slide on the bobbin cover. Raise the feed teeth.

Trouble Shooting

Always Start by Checking the Needle

- Always start with a new needle as soon as you discover that a stitch is not what you expected. Test sew on a scrap of the fabric you are sewing. Check that you have chosen the correct needle and see that it is correctly inserted. See page 10.

Unattractive Stitches

- The thread tension is not correct. See page 9.
- Make sure that the thread is not catching. Certain thread spools are unsuitable for spooling from the horizontal spool pin. Try instead with the vertical spool pin.
- The machine may be incorrectly threaded. Be sure to place spool holders correctly.

The correct threading is shown on page 7.

- Wrong bobbin thread. It should be of the same thickness as the upper thread.

The Needle Breaks

- You may have helped the machine to feed by pulling the fabric. The needle can strike against stitch plate and break. Change the needle. See page 10.

The Upper Thread Breaks

- Check the thread spool to see that it has not caught in any way.
- The needle eye may have sharp edges which cut the thread. If so, change the needle. See page 10.
- The upper thread is incorrectly threaded. See page 7.
- The upper thread may have too much tension. Refer to page 9.

The Thread is Knotted

- The hole in the stitch plate may be chipped and have sharp edges. We recommend that you replace it.

The Bobbin Thread Breaks

- The bobbin thread may be incorrectly threaded. See page 8.
- The stitch plate hole is damaged. See "Upper thread breaks".

Irregular Bobbin Winding

- This may be due to poor quality thread. When sewing with cotton thread, increase the thread tension.
- The machine is not correctly threaded for bobbin winding. See page 7-8.

The Fabric Puckers

- The upper thread tension is too tight. See page 9 for correct thread tension.

The Machine Does Not Feed the Fabric

- The stitch length is too short. Increase stitch length.
- The feed teeth may be lowered. Raise them by turning the stitch length dial to the left.
- The feed teeth are full of dust and dirt. Clean with the brush. See page 26.

The Seam is Too Loose – Fabric Layers Not Held Together

- The thread tension is far too loose. Page 9 shows how to adjust the thread tension.

Machine Runs Sluggishly

- Dirt or lint has built up under the stitch plate. Loosen the plate and brush clean between the feed teeth and in the bottom area. See page 26.
- Dirt or lint has packed in the hook. Remove the bobbin and clean with the brush. See page 26.

Expert Assistance

Have your machine "tuned up" regularly by your dealer.

If you have followed the preceding points and still do not get satisfactory results, you should contact the dealer where you bought the machine.

When the machine is being checked, it is a great help if it can be test sewn under as similar conditions as possible as when you used it.

Remember to take a sewing sample along with you, preferably of the fabric and with the thread you intend to use.

A sewing sample will often give much better information than words.

Non-original Parts and Accessories

The warranty does not cover any defect or damage caused by use of non-original accessories or parts.

Declaration of Conformity

Herewith we confirm that this Sewing Machine in its essential parts, fulfils the Low Voltage Directive 73/23/EEC, EMC directive 89/336/EEC and the CE Marking Directive 93/68/EEC.

This confirmation is based upon Certificate or Technical Construction Files, performed by SEMKO.

The complete archive file is drawn up and maintained by:

VSM Group AB
SE-561 84 Huskvarna
Sweden

We reserve the right to change the machine equipment and the assortment of accessories without prior notice, or make modifications to the performance or design.

Such modifications, however, will always be to the benefit of the user and the product.



Visit our web site www.husqvarnaviking.com for complete instructions.

VSM Group AB • SE-561 84 Huskvarna, Sweden
www.husqvarnaviking.com

412 77 78-26 A • InHouse • © 2003 VSM Group AB • All rights reserved • Printed in Sweden on environmentally-friendly paper

