

EXPENSIVE TOYS, LTD.
1709 Marshall Court
Annapolis, MD 21401
(301) 849-8050

User's Manual

DAHON FOLDERS

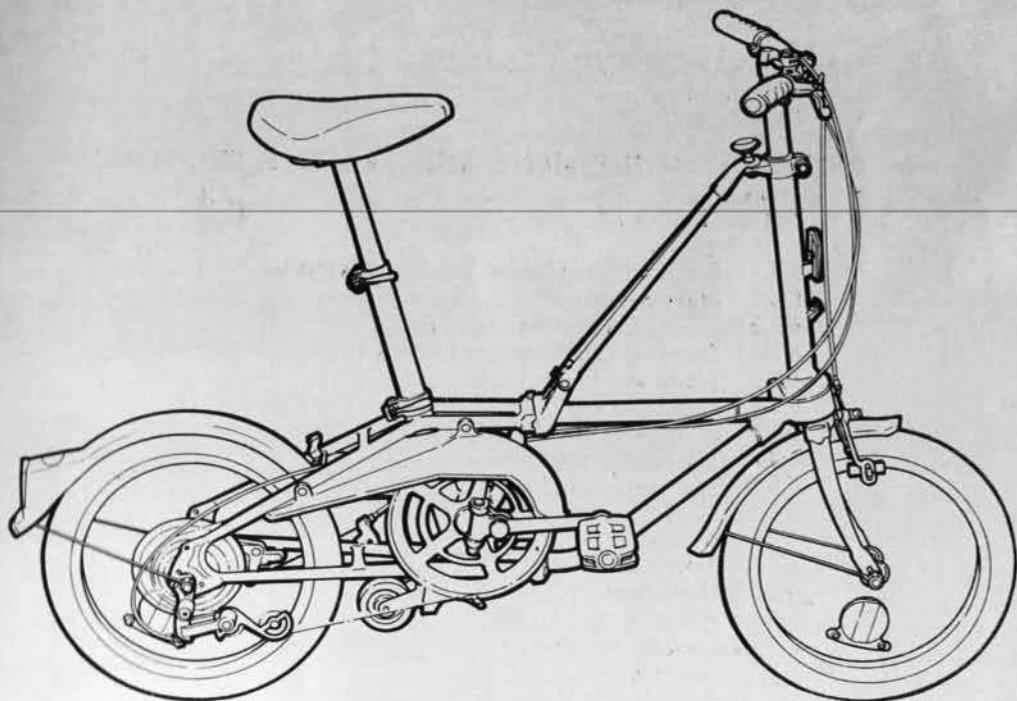

Warning: Do not ride before fully adjusting and securing all parts, especially latches.

LIMITED WARRANTY

The DAHON California, inc. (herein after called DHCI) warrants the front and rear bicycle frames (exclusive of latches, clamps and handlebar brace) and front fork to be free from defects in material and workmanship for a period of L-TYPE (five) 5 years from its original purchasing date.

All other standard bicycle parts (except tires, tubes, caster wheel assembly and plastic mud and chain guards) are warranted against defects in material and workmanship for (three) 3 months from the date of its original purchase.

Extent of coverage:

During the warranty period, DHCI will replace or repair any component to which this warranty applies if it is determined to have defects in material or workmanship. This will be done at no cost to you except labor and/or shipping charges (if applicable).

Procedure:

If a defect is discovered on an item which is covered by this warranty during the warranty period, follow the procedure listed below:

- A) If the bicycle was purchased from an authorized DHCI dealer capable of bicycle servicing, bring your bicycle along with the proof of date of purchase to the dealer. If the replacement of repair is determined by the dealer to be covered by this warranty, and such determination if verified by DHCI, servicing will be carried out in accordance with the warranty.
- B) If the above is not possible, write to DHCI for assistance:

DAHON California, Inc.
2949 Whipple Road
Union City CA. 94587
U.S.A. Tel:415-471-6330

Your letter must include a photocopy of the proof of date of purchase and Warranty Card, and must state your full name and address, a description of the item and defect, and the date and conditions in which the defect occurred.

- C) Upon inspection, the dealer may determine that the warranty does not apply, in which case you will be advised of the reason and subsequent

cost of repair. You may then notify the dealer as to whether or not you wish the necessary repairs to be made. If for any reason it is necessary to ship your bicycle, or any of its parts, under no condition is DHCI responsible for damages, loss and/or shipping fees. If provisions for return shipping are not made in advance, the items will be returned to you C.O.D. and you must pay the shipping cost upon receipt. If the C.O.D. and other charges are not paid and the item(s) is returned to the dealer, he may then dispose of the item(s) as he wishes.

Exclusions, limitations and other rights;

- A) This warranty does not cover tires, tubes, caster wheel assembly and plastic mud and chain guards. Nor does it cover any defect of failure caused by accident, misuse, abuse, neglect, normal wear and tear or alterations of any type, including, but not exclusive of, improper servicing or alteration for stunt riding, dirt riding or any similar activities.
- B) DHCI's only responsibility, if any, to terms contained in this warranty is the replacement of defective parts as indicated above. Under no condition shall the cost of fulfilling these terms exceed the original purchasing price of the bicycle. Nor does DHCI take any responsibility for any consequential or incidental damages including, but not exclusive of, damages to property or damages for personal injuries.
- C) This warranty is in lieu of all other warranties, whether written, spoken or implied. There are no promises, terms or conditions other than those contained herein.
- D) Some states do not allow limitations on how long an implied warranty lasts or the exclusion or limitation of incidental or consequential damages, so the above limitations or exclusions may not apply to you.
- E) This warranty gives you specific legal rights and you may also have other rights which vary from state to state.

TABLE OF CONTENTS

1. INTRODUCTION
2. RESPONSIBILITIES AND SECURITY
 - 2.1 Owner's Responsibility
 - 2.2 Protection Against Theft
 - 2.3 Lighting and Reflectors
3. HOW TO OPERATE DAHON FOLDER
 - 3.1 Unfolding
 - 3.2 Folding
 - 3.3 Transtating
4. PREPARING TO RIDE
 - 4.1 Safety and Parts Inspection
 - 4.2 Getting the "Feel" of the Bike
 - 4.3 Tire Inflation
 - 4.4 Rules of the Road
5. MAINTENANCE AND CLEANING
 - 5.1 Maintenance
 - 5.2 Cleaning and Care
6. ASSEMBLY, ADJUSTMENT AND TROUBLE SHOOTING
 - 6.1 Tools
 - 6.2 Nut and Bolt Guide
 - 6.3 Servicing Guide
 - 6.3.1 Bottom Bracket and Crankshaft Assembly
 - 6.3.2 Brake System
 - 6.3.3 Saddle and Seat Post System
 - 6.3.4 Seat Post Quick Release Clamps
 - 6.3.5 Frame and Frame Latch
 - 6.3.6 Handlebar and Stem
 - 6.3.7 Brace, and Coupling Pin
 - 6.3.8 Steering System
 - 6.3.9 Sprockets and Chain
 - 6.3.10 Hubs
 - 6.3.11 Wheels
 - 6.3.12 Tires and Tubes
 - 6.3.13 Mudguards
 - 6.3.14 Reflectors and Lamp
 - 6.3.15 Dynamo Installation
 - 6.3.16 Caster Wheel
7. SPECIFICATIONS
8. PARTS LIST
 - 8.1.E-1 8.2.E-3 8.3.E5
9. LIMITED WARRANTY (BACK COVER)

1. INTRODUCTION

"Congratulations, you have just acquired a fine product. Your DAHON Folder comes to you fully assembled and is easily adjusted to run smoothly. For full enjoyment and safety of this product, please read and follow all of the instructions and helpful hints contained in this manual. Pay special attention to items denoted; (caution) and (warning).

Caution: To prevent component failure or damage.

Warning: To prevent injury to the rider or others.

Although your DAHON Folder is easy to ride for people of all ages and sizes, riders should be aware that the DAHON Folder is more maneuverable and responds faster than the typical large wheel bicycle and may require some initial familiarization.

2. RESPONSIBILITIES AND SECURITY

2.1 Owner's Responsibility

1. Follow the instructions in this manual and any other literature supplied with this bicycle.

The owner is responsible for performing specified maintenance service to keep this bicycle in safe operating condition.

2. The warranty card for your Folder by DAHON should be completed and returned to enjoy your privileges.

Warning: Prior to riding, check equipment "Safety and Parts Inspection" (Sec. 4.1).

2.2 Protection Against Theft

1. Record the serial number of your bicycle _____. It is located on bottom bracket (F250M50).

2. Record name and location of store where purchased, and date of purchase: _____

3. Register your bicycle with your local law enforcement agency, and obtain license if required. License No. _____ Place registered: _____

2.3 Lighting and Reflectors

Almost all jurisdictions require use of pedal, wheel, front, and rear reflectors. An adequate electric headlamp is usually required for riding after dark.

An electric taillamp, even if not required, is recommended for your safety and visibility. The use of light colored or reflective clothing is also strongly advised. A Dnyamo Light Set can be purchased from your local DAHON dealer.

3. HOW TO OPERATE DAHON FOLDER

The following instructions explain what we feel is the most efficient way to fold and unfold your DAHON Folder while standing on the left side of the bike.

3.1 Unfolding

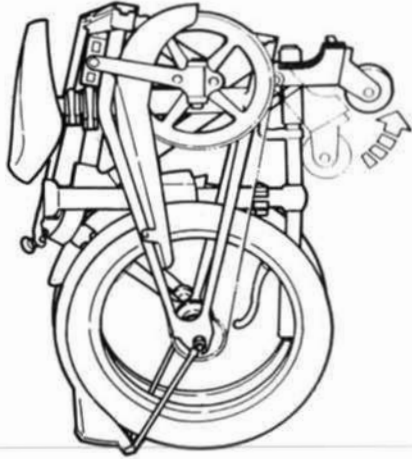
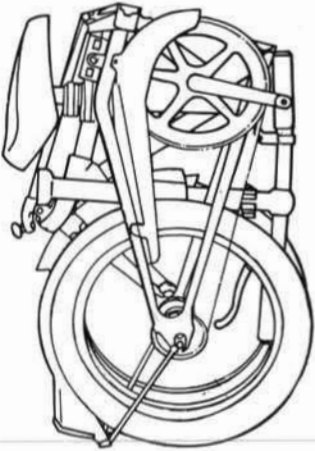

1. Stand on the back of the Folders Bike as shown.

2. Flip out the caster wheel.

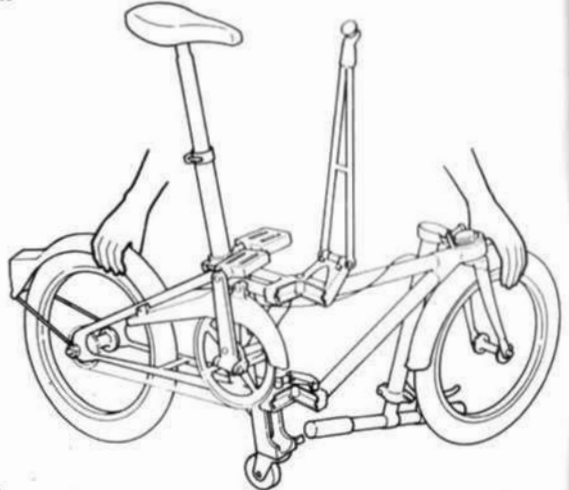
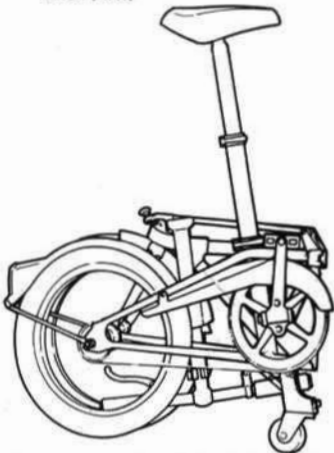

3. Adjust the seat to the desired height by securing the seat post with the seat latches. Never exceed the "Safety Mark" engraved on the telescopic seat post.
4. Using rear and castor wheels for support, swing open front half of bicycle and straighten out.



5. Push mid-frame latch horizontally with thumb until locked securely.



6. Raise handlebar to vertical position, and engaged the brace by pushing down on the knob.
Warning: The knob must pop up entirely to indicate latching is secure. Test this by pushing and pulling on the brace.



7. Adjust the handlebar and secure the handlebar quick release clamp.



8. Swing the right crank downwards.

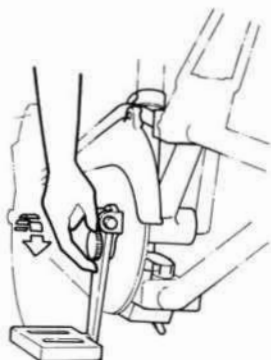

9. Lock crank in place by twisting and securing the crank bolt

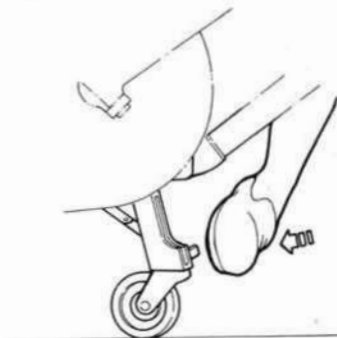

10. Retract caster wheel by stepping down on lever.

Warning: Failure to retract the caster wheel before riding can seriously damage it.

3.2 Folding

To fold DAHON Folders, you may use in reverse basically the same method as unfolding. Outlined hereafter is an easy way to fold the DAHON Folder.

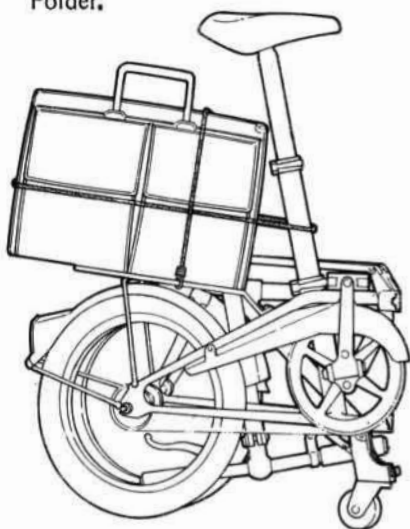

Fig. 1

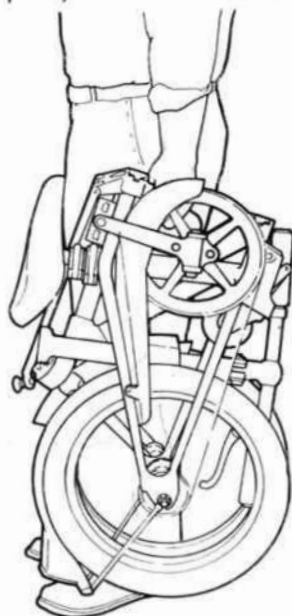

Fig. 2

3.3 Transportating

There are two modes of transporting your DAHON Folder : Pushing and Carrying.

- 1) Your DAHON Folder can be pushed along beside you in a folded state by using the caster wheel and by extending the seat post to a convenient height (Fig. 3). As the caster wheel is not designed for rough terrain, the bike should either be lifted, or tilted backwards, to run on the 2 large wheels when crossing rough areas.
- 2) In some areas where your DAHON Folder cannot be pushed, it can be easily carried by hand. By completely folding the bike and raising it to a standing position, you can grasp the carrying bar with either hand and easily carry the bike with you anywhere (Fig. 4).

Your DAHON Folder in its folded state is very portable and can be placed compactly lying, standing or leaning in all sorts of small convenient places. It is easily fitted under bus seats, subway seats, in car trunks, lockers, and any space measuring at least 10" x 18" x 28".

4. PERPARING TO RIDE

4.1 Safety Points And Parts Inspection

To ensure your safety and protect your new product from unnecessary wear or damage, carefully check all of the following points before riding your DAHON Folder. A conscious inspection of these items is essential before every ride.

	(OK)	(FIX)	(Ref. Sec.)
1. Latches and clamps firmly fastened, no slipping or cracks.			
A. Mid-frame latch	()	()	(6.3.6)
B. Upper and lower seat post clamps	()	()	(6.3.5)
C. Handlebar clamp	()	()	(6.3.8)
D. Handlebar brace latch	()	()	(6.3.10)
E. Right crank Thumb Screw	()	()	(6.3.3)
2. Tires, front and rear:			
A. Inflation pressure (45 psi)	()	()	(6.3.13)
B. Valve straight	()	()	(6.3.13)
C. Adequate tread, no cuts	()	()	(6.3.18)
D. No uneven wear, bulges	()	()	(6.3.13)
E. Properly seated on rim	()	()	(6.3.13)
3. Wheels, front and rear:			
A. No wobble side-to-side	()	()	(6.3.12;6.3.11)
B. No "hop" up-and-down	()	()	(6.3.12)
C. No dents or bulges	()	()	(6.3.12)
D. Freedom of rotation, no tight spots	()	()	(6.3.14;6.3.13; 6.3.2)
4. Spokes, front and rear:			
A. Even tension	()	()	(6.3.12)
B. None missing or broken	()	()	(6.3.12)
5. Frame, fork and brace:			
A. No bent components	()	()	6.3.6;6.3.8; 6.3.9)
B. No cracks	()	()	(6.3.6;6.3.8; 6.3.9)

C. No gaps between components	()	()	(6.3.6,6.3.8; 6.3.9)
D. Brace movement firm, smooth – no wobbling	()	()	(6.3.8)
E. Knob	()	()	(3.1,6.3.8)
6. Brakes, front and rear:			
A. Mounted properly, no loose bolts or parts	()	()	(6.3.2)
B. Shoes grip firmly, no slipping	()	()	(6.3.2)
C. Release action solid, equal	()	()	(6.3.2)
D. No excessive wear	()	()	(6.3.2)
E. No rubbing at any point	()	()	(6.3.2)
F. No broken or kinked cables	()	()	(6.3.2)
G. Cables attached properly	()	()	(6.3.2)
7. Steering and handlebar:			
A. Smooth action of steering head bearing	()	()	(6.3.9)
b. Firm, not loose or binding steering head bearing	()	()	(6.3.9)
C. No play in handlebar post, or handlebar	()	()	(6.3.7,6.3.8)
D. Adjusted to proper height and latched	()	()	(3.1,6.3.8)
E. Properly positioned brake and gear controls	()	()	(6.3.2,6.3.11)
F. Tightened brake and gear cables and mounts	()	()	(6.3.2,6.3.11)
G. Smooth telescope action	()	()	(6.3.7,6.3.8)
H. No cracks or bent members	()	()	(6.3.9,6.3.7; 6.3.8)
8. Saddle and post:			
A. Properly adjusted	()	()	(3.1,6.3.4; 6.3.5)
B. No slipping or wobbling	()	()	(6.3.5)
C. No cracks or excessively worn parts	()	()	(6.3.4,6.3.5)
D. Not excessively extended	()	()	(3.1)

9.	Pedals; left and right:			
	A. Firmly lightened into crank	()	()	(6.3.3)
	B. Bearings turn smoothly	()	()	(6.3.3)
10.	Crank, chain wheel, and bottom bracket bearings:			
	A. Crank firmly latched	()	()	(3.1;6.3.3)
	B. No loose or wobbling parts, pins secure	()	()	(6.3.3;6.3.1)
	C. No bends or cracks	()	()	(6.3.3)
	D. Firm, but not binding, bottom bracket bearings	()	()	(6.3.1)
	E. No worn, broken or bent teeth	()	()	(6.3.10)
11.	Hubs:			
	A. Mounting nuts properly tightened	()	()	(6.3.11)
	B. Cog straight; no broken, cracked, or bent teeth	()	()	(6.3.11)
	C. Smooth spinning action	()	()	(6.3.11)
	D. Locking nuts & sleeves properly tightened	()	()	(6.3.11;6.3.12)
12.	Chain:			
	A. Properly lubricated	()	()	(5.2;6.3.10)
	B. Attached securely, not too loose or tight	()	()	(6.3.10)
	C. No rubbing against frame or guard	()	()	(6.3.10)
13.	Mudguards:			
	A. No cracks	()	()	(6.3.14)
	B. No rubbing	()	()	(6.3.14)
14.	Carrier:			
	A. No cracks	()	()	(6.3.6)
	B. Securely fastened	()	()	(6.3.6)
15.	Reflectors:			
	A. Clean	()	()	(6.3.15)
	B. Tightly fastened at proper angles	()	()	(6.3.15)
16.	Caster wheel assembly:			

- | | | | |
|---|-----|-----|--------------|
| A. Raised before riding | () | () | (3.1,6.3.16) |
| B. Pins and bolts fastened,
working properly | () | () | (6.3.16) |
| C. Elbow spring functioning | () | () | (6.3.16) |

Warning: To avoid possible injury, all faulty points that can affect safety must be corrected before riding.

4.2 Getting The "Feel" of the Bike

Your **DAHON Folder** is a high performance bicycle designed for commuting and recreational use on paved roads (Warning: fast riding on unpaved areas could result in mechanical damage and bodily injury).

Although your **DAHON Folder** is easy to ride for people of all ages and sizes, riders should be aware that the **DAHON Folder** is more maneuverable and responds faster than the typical large wheel bicycle and will require some initial familiarization. You can get the "feel" for the Dahon's steering and handling by testing the bicycle on a flat open area. **DAHON** strongly recommends that riders wear a hard shell helmet, brightly colored clothing and shoes when riding. At night, use lights and reflectors. In wet weather, allow more distance for stopping.

It is also suggested that you practice folding and unfolding bicycle so that you can do it quickly and efficiently. After sufficient practice, you should be able to fold or unfold the **DAHON Folder** in 10-20 seconds.

4.3 Tire Inflation

Prior to sitting upon or riding **DAHON Folder**, the tire pressure must be checked. The basic pressure required is molded onto the tire. However, a little more pressure may be required for a heavier person, while a little less may be needed for a person of small stature. If your tire pressure is significantly below the basic range or you feel that the tires do not support your weight well, it is best to use a hand pump to pump in additional air. Gas station pumps supply too much air too quickly and may rupture your tire tube. If a gas station pump must be used, however, add air into the tire in small spurts until the desired pressure is reached.

4.4 Rules of the Road

There are 12 basic rules of cycling in the U.S. You should contact your local law enforcement officials for any additions to these rules.

Warning: Failure to obey these rules of the road could result in injury to the rider or to others.

1. Obey state and local traffic regulations, signs, and signals.
Check with your local police on bicycle licensing, inspection, and riding on sidewalks

2. Keep to the right except for left turns.
Ride with traffic, not against it. Ride single file in a straight line. Ride as close as practicable to the curb, but at a distance which still gives room for maneuvering.
3. Watch for car doors opening.
Always be prepared to stop or turn quickly if necessary. Watch for and anticipate cars. When riding on or near the sidewalk, watch for cars and other bikes that pull into or out of driveways. Do not assume that you have been seen.
4. Use hand signals for turns or stops.
Advise motorists what you plan to do by giving proper signals 100 feet before turning or stopping.
5. Be extremely careful at intersections.
If traffic is heavy, walk your bicycle with pedestrian traffic. Look both ways when crossing streets and observe approaching cars.
6. Avoid: drain grates, soft road edges, gravel or sand, leaves (especially when wet), wet and raised manhole covers, pot holes, ruts, uneven paving and any other road surface hazards.
Avoid these hazards to prevent loss of control or damage to your wheels. Cross railroad tracks at right angles to prevent loss of control.
7. Use extreme caution at dusk and at night.
Be thoroughly familiar with the controls on your bicycle. Ride only when necessary at night and avoid heavy traffic. Vision is quite limited at dusk and at night, so be very careful to avoid any road hazards. Make sure your bicycle is equipped with properly positioned and clean reflectors on pedals and side reflectors on wheels. The purchase and installation of an adequate headlight and taillight is strongly recommended and required by law in most areas. Wear light-colored or reflective clothing. Ride slowly and ride only on streets familiar to you. Check local laws regarding riding at night. Do not let a coat or other clothing hang down and cover your rear reflector.
8. Use extra caution in wet weather.
Ride slowly on damp surfaces as tires will slip easily. Apply brakes sooner than normal as a greater stopping distance is required, especially if your brake shoes are wet.
Warning: If the front brake is applied too strongly, the bike might flip forwards.
9. Give pedestrians the right-of-way, make a sound loud enough to alert any pedestrians that you want to pass.
Do not ride too close to pedestrians. Don't park your bicycle where it will get in someone's way.
10. Don't
 - Carry passengers
 - Carry items or attach anything to your bicycle that might hinder your vision or control.

- Hold onto or attach your bicycle to any car, truck, or other vehicle in order for it to pull you along.
 - Carry extra clothing where it can hang down and jam the wheel.
 - Ride with both hands off the handlebars.
 - Wear head phones.
11. Ride a safe bicycle and wear proper clothing.
Make sure your bicycle fits you and that all parts, especially the brakes, are adjusted and working properly. Make sure loose fitting clothing (especially your right pants leg) does not catch in moving bicycle parts.
 12. Watch out for the other guy, ride defensively.
Watch the car or bicycle in front of you and be prepared to take defensive action. Don't follow a car or another bicycle too closely.
Be especially aware of traffic approaching from behind in case you must swerve to avoid something.

Warning: This bicycle has been designed for general transportation and recreational use. It has not been designed to withstand abuse associated with stunt riding and jumping or organized competitive events. The user is warned that he assumes risk for injuries, losses and damage from such uses.

5. MAINTENANCE AND CLEANING

5.1 *Maintenance*

In addition to the before-riding "Safety and Parts Inspection" (second 4.1 of this manual), a thorough inspection of all inner and outer working parts should be performed by a professional bicycle dealer after 3 months, 6 months, 1 year and every 6 months thereafter. Included is a sample inspection form. Regularly scheduled inspections are necessary for the safe use of a mechanically complex vehicle such as your DAHON Folder.

SAMPLE INSPECTION FORM

DATE:

ITEM	RESULT	CORRECTION	COST
FRAME AND LATCH			
STEERING SYSTEM			
HANDLEBAR SYSTEM			
SADDLE, SEAT POST SYSTEM			
DRIVE SYSTEM			
WHEEL SYSTEM			
BRAKE SYSTEM			
CASTER WHEEL SYSTEM			
LAMP AND REFLECTORS			

DEALERSHIP'S NAME:
 COMPANY REGISTRATION NO:
 DEALER'S SIGNATURE:

TOTAL COST:

5.2 *Cleaning and Care*

Because of the great deal of contact between you and your bike, your clothing and hands are likely to get soiled if the bike is coated with oil and dirt. To prevent this from happening, carefully clean the bike of dirt and oil deposits. The use of solvents and other cleaners will help dislodge dirt and oil. Use a soft rag and a toothbrush to thoroughly clean all parts of the bike. After you ride through particularly dirty and dusty areas or a rainstorm, the chain should be given special attention. If you own a chain breaker tool, the chain can be removed entirely for cleaning. To keep your bicycle looking brand new and to keep dirt from adhering, it is recommended that you use a high quality car wax on your bicycle.

To keep your bike running smoothly, it is necessary to lubricate all the moving parts. Thoroughly clean the parts to be lubricated, and remove all foreign particles. Light oil of SAE 20 consistency can be used as a lubricant for most parts. Frequency of lubrication depends on the amount of use and weather encountered.

Warning: Do not use gasoline for cleaning. Avoid fumes and clean out of doors if possible.

Caution: Do not allow any solvent or oil to get on the wheels or caster wheel; if you do, clean immediately.

6. ASSEMBLY, ADJUSTMENT AND TROUBLE SHOOTING

6.1 Tools

Your DAHON Folder is shipped completely assembled and with air in the tires. Brakes and gear shift should already be adjusted. Your dealer should check each point in the safety list, but you will wish to have some tools for subsequent adjustment and safety checks (a minimum shown below).

For your convenience, DAHON does sell a portable tool set.

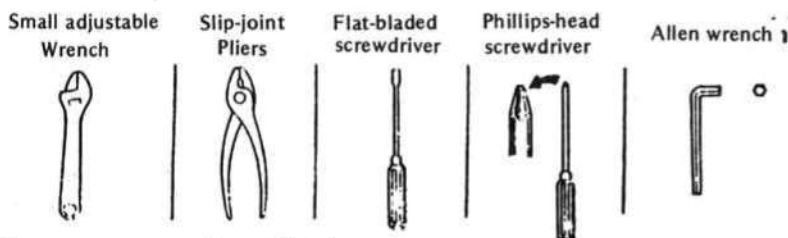

(Jaws must open at least 9/16")

Caution: When using an adjustable wrench, make sure wrench, and wrench jaws are tight in order to prevent damage to bolts and nuts.



6.2 Nut and Bolt Tightening Guide

Nuts and bolts must be adequately tightened for strength and security, but not overtightened to the point of failure, or crushing or expanding tubes. The length of wrench, times the force applied at the end of the wrench, gives the torque applied measured in inch-pounds.

Typical Examples:

- 8mm or 5/16" thread: 200-220 IN-IBS.
- 9.5mm or 3/8": 250-280
- 1/2" Pedal Thread: 260-280
- 9/16" Pedal Thread: 450-500
- 6mm Brake Bolt: 150-170
- 5mm Brake Cable and Shoe: 120
- 7mm Crank Cotter Nut: 180-190
- Front Wheel Nut: 200-220
- Rear Wheel Nut: 250-280

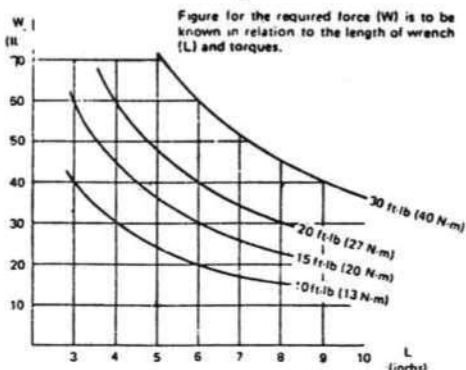

To prevent nuts and bolts from coming loose. "Locktite" bond has been used wherever appropriate on your factory-built FOLDER After you have tightened any nuts and bolts, for utmost safety, it is strongly recommended that you do the same.

6.3 Servicing Guide

The following sections include detailed information needed for the disassembly, maintenance, adjustment, trouble shooting and repair of the DAHON Folder. Detailed sketches have been provided, while reference to the exploded view of the entire bicycle is available in section 8 of this manual.

Caution: Do not attempt to disassemble, adjust, or repair parts without first having adequate tools and mechanical background.

6.3.1 Bottom Bracket Crankshaft Assembly

A. Disassembly

To disassemble, first remove 2 split pins (U121 E50) from the caster wheel bracket (U110E50) and elbow (U310 E50) and remove their adjoining pins (U120 E50 & U340 E50). With a small wrench, remove the elbow spring (U360 E50) and pull out the caster wheel (U100 E50). With a small adjustable wrench, loosen and remove the left pedal (C320 M50) by turning it clockwise. Next, use lock ring pliers to remove the lock nut (A270 M50), washer (A260 M50), and bearing caps (A240 M50) respectively.

Disassembly: Use a Phillip's screwdriver and a wrench to loosen the crank pin (C121-M) from the nylon nut (F620). Remove the washers (C123 & C125). Unscrew and remove the crank screw (C111) and E-ring (C112). Tap the crank pin with a hammer to remove it completely from the crank assembly.

B. Adjustment, Trouble Shooting and Maintance

Lubrication of these bearings is also very important as dirt, grime or worn bearing grease can cause damage to bearing races. Each time this assembly is dismantled, all parts should be thoroughly cleaned dried and re-greased. This process should be done at least once every 6 months, or more if there is any grinding or tight movement after proper adjustment.

If excessive looseness or tightness exist after parts are lubricated and adjusted, one or more of the foremented parts is damaged and should be replaced at once. Failure to replace a worn part will accelerate wear of other inner-working bottom bracket parts.

If excessive looseness or tightness exist after parts are lubricated and adjusted, one or more of the fore mentioned parts is damaged and should be replaced at once. Failure to replace a worn part will accelerate wear of other inner-working bottom bracket parts.

6.3.2 Brake System

The brakes are one of the most important parts of your bicycle. To be sure that the brakes work well when you really need them, perform all the adjustment steps in this section exactly as instructed.

Warning: If brakes do not work well after making the following adjustments, have brakes repaired or replaced at a bicycle service shop.

Your DAHON Folde may use the two types of brakes, a caliper and for band brake.

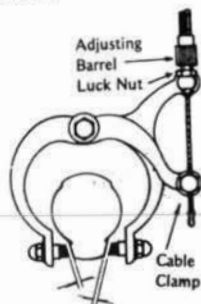

A. Adjustment of caliper Brake

For best braking action, it is vital that brake is mounted so as to leave a distance of approximately $1/16''$ between the shoe and the rim. (Fig. 1).

Note: If either wheel is not in alignment with the bicycle frame, rubbing will occur between the rim and the brake shoes. To correct this, re-align the wheel as instructed in section 6.3.12 of this manual.

If the front brake shoes are not equally spaced, tap down lightly on one side of the "return spring" with a screwdriver. If this does not correct the problem, slightly loosen the mounting bolt and repeat the tapping procedure. For the rear brake, adjustment should be made by slightly loosening the mounting bolt and tapping the top of the brake arm until the brake shoes are evenly spaced. Always be certain that the front mounting bolt is securely tightened before riding the bike. If one of the mounting bolt is stripped and cannot be properly tightened, or if it is damaged or bent, replace it immediately.

B. Minor Cable Adjustment

Now that the brakes are properly centered, if the space between the shoes and the rim is more or less than $1/16''$, it is necessary to adjust the brake cable.

A minor adjustment can be made by first loosening the locknut until it is against the adjusting barrel (Fig. 2), being careful not to turn the adjusting barrel so far that it comes out of the part that it's threaded into, or out of the locknut; turn the barrel in the direction which positions the brake shoe $1/16''$ from the rims. If this minor adjustment does not suffice, a more complete cable adjustment should be done by a qualified mechanic.

C. Changing and Adjusting Brake Shoes

If brake shoes have no thread or if any part of the rubber block wears down to $1/8''$ from the metal backing, it is necessary to replace them. To obtain the performance built into your bicycle, be sure to only use top quality brake shoes.

Remove the brake shoes by using a wrench to detach the nut and washer. After positioning new brake shoes, replace the washer and nut to their original location, being careful to observe the adjustment instructions illustrated below.

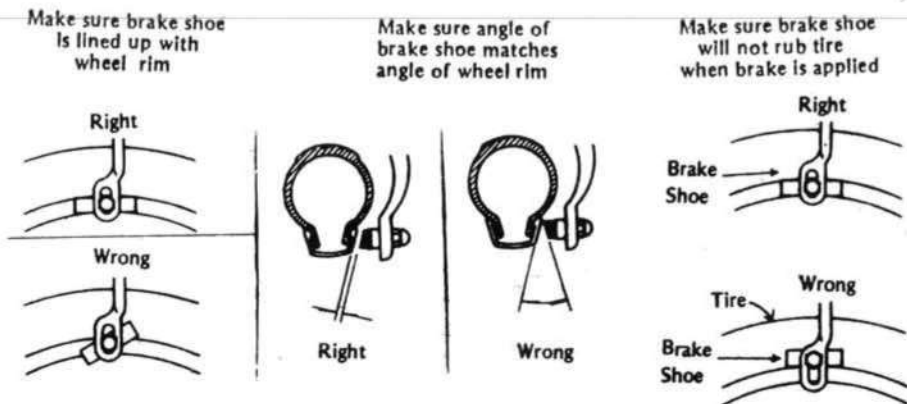

D. Adjustment of Brake Levers

Brake and gear control levers must be fixed into a specific position for proper folding of DAHON Folder. If they are moved out of their proper position they will interfere with folding and unfolding. To adjust a lever, simply loosen the mounting nut and maneuver to the proper position. Always be certain that mounting nuts are tight — if levers can be budged with proderate force, they must be further tightened.

There is a metal anchor fastened to the end of the cable wire which fits inside the brake lever. You'll have to look up under brake lever to see the anchor. Make sure that each anchor is properly seated in its recess, and has not jumped out. If anchor is out of position, squeeze caliper arms in against wheel rim in order to slacken the cable wire and allow repositioning of anchor.



Firmly squeeze each brake lever and, if either one touches the handlebar grip, recheck cable adjustment.

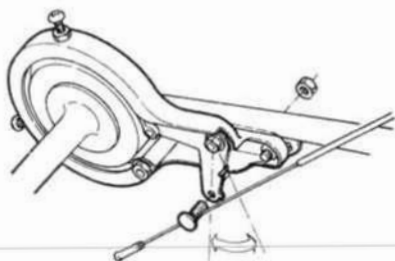

E. Adjusting the Band Brake

Return the barrel screw (B340 M50) to its original position and adjust the barrel, and screw B respectively.

F. Other Maintenance and Lubrication

If the brakes become loose, you may find it necessary to tighten the barrel screw (B340 M50).

It is important to often check the brake cables for broken strands. If the cable wire is rusted or the cable sheath (covering) is bent and can't be straightened without damaging the cable, it is necessary to replace the brake cable at once.

The brake pivots and cable should be lubricated once every 4 months, or more often if the brake does not operate smoothly and freely. To lubricate the cable, put several drops of light-weight oil into each end of the cable sheaths or take it to a service shop so that sheaths can be removed and cables thoroughly inspected and lubricated.

Warning: Do not get any oil on caliper brake shoes as it will reduce braking effectiveness. Clean oil from the shoes or rim with a rag wet with soapy water, and rinse.

Warning: If brakes do not work well, have them repaired or replaced at a bicycle service shop before riding your bike.

6.3 3 Saddle and Seat Post System (Excluding Clamps)

A. Disassembly and Assembly

Remove saddle from upper seat post (P-200) by loosening saddle nuts (P-120) and tapping upwards on saddle. Remove upper and middle seat post tubes by loosening quick-release clamp bolts P-320 and F-410 respectively.

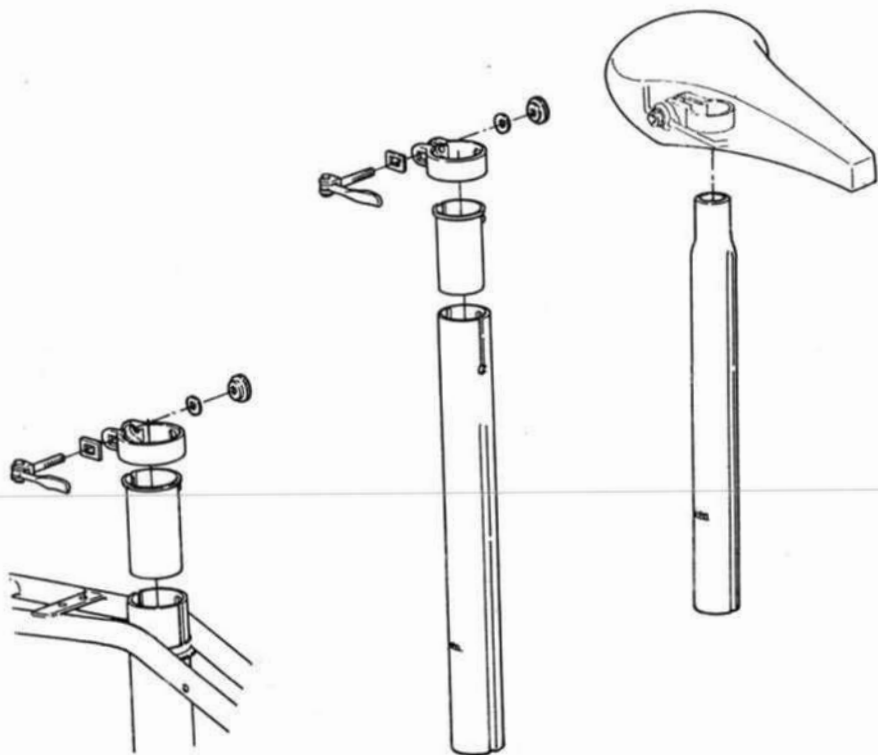

B. Adjustment, Trouble Shooting and Maintenance

Durable nylon sleeves (P330-M and F300-M) have been placed between the sliding seat posts and their respective seat post clamps. In order to keep the seat posts aligned, these nylon sleeves have an extrusion which fits into the groove built into the seat post. If these sleeves become worn or cracked, they must be replaced.

If clamps are all properly adjusted (see Sec. 6.3.5) and nylon sleeves in good condition, but the seat post fails to slide smoothly, one or more of the seat posts have probably been bent or dented. If the piece cannot be straightened without damaging or weakening it, replacement is necessary.

To adjust the saddle, simply loosen the saddle nut, adjust the saddle to your comfort, and re-tighten the nut. For your safety, make sure that the saddle bolt and nut are not bent, rusted, excessively worn and that threads are not stripped. Also be certain that the braces-which clamp the saddle in place (located between the saddle nuts and saddle clamp) are properly positioned and are not bent, rusted or otherwise damaged. Always be certain the bolt is properly tightened with 200-220 foot pounds of torque.

6.3.4. Seat Post Quick Release Clamps

A. Disassembly

Remove in order the adjusting nut (H334M50), clamp bolt (H332M50) and the square washer (H333M50).

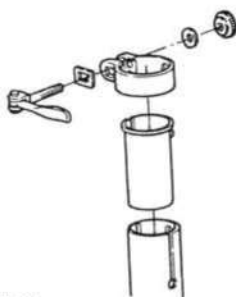

Washer Bolt Adjusting Nut

B. Adjustment, Trouble Shooting and Maintenance

If properly adjusted, the seat posts should slide freely when the clamp is released, but hold steady under the pressure of a person weighing up to 250 pounds when the clamp is tightened. If this is not the case, release the clamp and adjust the tension by turning the "adjusting nut" (P-332 or F-430) by means of a wrench. Be careful not to tighten the nut to such a degree that sliding becomes difficult. A small amount of bearing grease applied to the camming surfaces of the clamp will extend its useful life.

After extended use, the inner working of the clamp bolt may wear down to the point to where clamping action is limited. In such case, it is necessary to replace the bolt, nut and washer. It may also be possible that inspection shows that replacement of the nylon sleeve is needed first.

Warning: Always be certain that the clamps are secured and properly adjusted each time before riding your bike.

6.3.5 Frame and Frame Latch

A. Disassembly

To disassemble the frame, first remove the various components attached to it, according to their various subsystems and disassembly instructions. Then, unlatch the frame latch assembly and turn the entire frame upside down. Remove the 2 C-clip retainers. Remove frame latch assembly by alternately tapping the 2 pins until the entire latch assembly is extracted downward.

To disassemble the frame latch, unscrew the rear pin and counter-threaded nut.

To separate the 2 halves of the frame, first remove the 2 nylon nuts (F620 M50), and then tap out the 2 pins (F610M50).

B. Adjustment, Trouble Shooting and Maintenance

The only component to adjust on the frame is the frame latch. When properly adjusted, the latch should not be able to pop open without first depressing the safety spring (F710M50). Moreover, the front and rear top lugs should be flush, with no gaps, and there should be no wobbling between the front and rear frames.

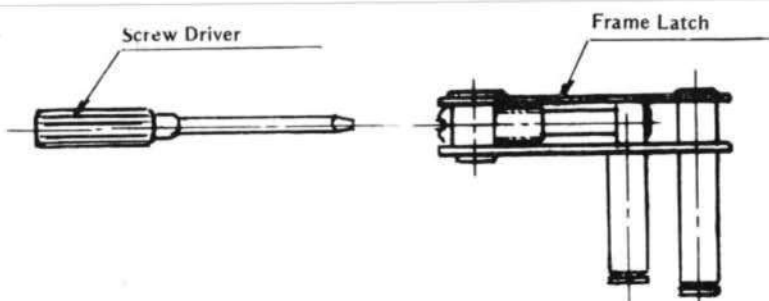

To adjust the frame latch, first release it, and then use pliers or a screwdriver to turn the counter-threaded adjusting nut clockwise to tighten, or counterclockwise to loosen. When adjustment is complete, add a drop of "Loctite". Double check to make sure that the safety spring holds the frame latch securely in place. If the latch is in place, but the spring fails to hold it securely, remove the spring by detaching F-720, and adjust the spring by bending it in or out.

Warning: Never ride the bike without the safety spring working properly.

After adjustments have been made, if gaps or wobbling between the front and rear frames still occur, replace or repair the following items.

- A) Top/bottom lug pins (F610M50) – worn to a point where a tight fit no longer exists; bent.
- B) Nylon nuts (F-620M50) or C-clips (F-870M50) – missing or loose.
- C) Counter-threaded adjusting nut – bent, stripped or excessively worn.
- D) Safety spring (F710M50) – loose or missing bolt and nut (F720M50' F730 M50); lacking tension.
- E) Front/rear frames—out of alignment.

Warning: Never ride the DAHON Folder without first making certain that the frame is sturdy and latch functioning properly.

6.3.6 Handlebar and Stem

A. Disassembly

Loosen the nut (H223M50) beneath the handlebar lug as shown in Fig 1, until handlebar (H110M50) can be freely removed. The angular orientation of the handlebar is critical to proper folding of the bicycle. A stretch mark should be made before loosening the nut so as to return to the correct orientation.

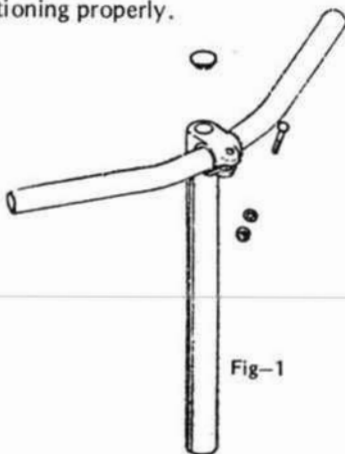

6.3.7 Brace and Coupling Pin

A. Disassembly

To separate the brace from the frame brace bracket (F160M50); remove the 2 cap head screws (H433M50), 2 clamps (H431M50) and the half sleeve (H432 M50).

Unscrew the lock nut (H346-1) from the A-frame fast base (H342-1) and remove the fast pin (H341-1).

B. Adjustment, Trouble Shooting and Maintenance

The handlebar quick release clamp is the same type as the seat post quick release clamps, and disassembly, adjustment, and maintenance procedures are the same.

The brace should be able to slide back and forth in the brace bracket smoothly but firmly. If this action becomes too tight (requires exceptional force or pounding to move) or too loose to stay up by itself, the brace should be adjusted by loosening or tightening the 2 clamp bands (H431M50).

If this adjustment does not cure the problem, check and replace worn brace bracket assembly parts (H433M50 bolts, H433M50 clamps, H432M50 sleeve, brace end, or F160M50 brace bracket).

When unfolding the bicycle, the brace head (H410M50) should cover snugly into the Handle Post Bracket on the steering column. If the brace head fast pin (H341-1) does not align with the handle post bracket hole (H310P-M) one or more of the following components are bent or out of alignment, and your bike should be taken to a dealer for adjustment or replacement of necessary

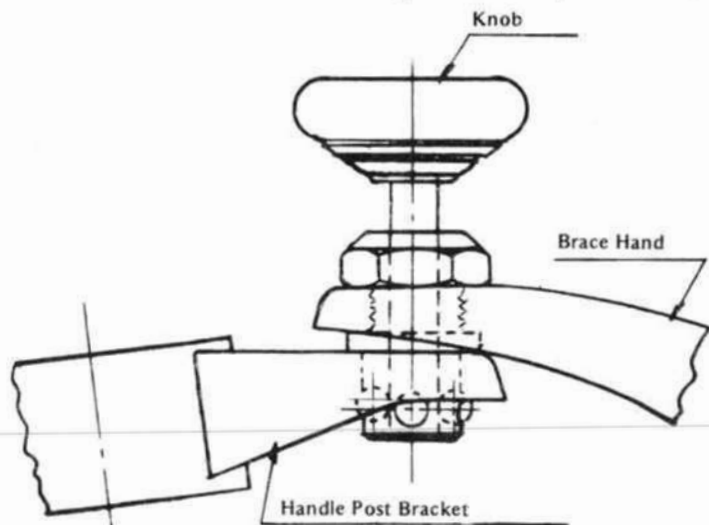

parts — brace, brace bracket, front frame, Handle Post Base, Handle Post Bracket or A-Frame Fast Ass'y.

If the brace is firmly fitted in bracket and all parts in alignment, but the steering column wobbles after unfolding the bicycle, check immediately the tightness of the lock nut of the steering coupler. If it is all right, then one or more of the following components are worn, bent or cracked, and should be replaced at once. A handlepost brace, Handle Post Bracket, or Handle Post Base. (see following section)

6.3.8 Steering System (Bearings, Steering Column Latch and Front Fork)

A. Disassembly

To remove the steering column, remove one of the 2 rings (S332M50) and tap the pin (S-330M50) out from between the handle post (H312M50) base and steering coupler (S320M50). Unscrew the 2 lock nuts (S340M50), remove steering coupler, unscrew bearing adjusting nut (S220M50), remove the 2 ball bearings (S210M50) and unscrew front fork.

Note: When assembling, be sure that the bearing adjusting nut (S220M50) is properly adjusted—not so loose that wobbling of the front fork exists, but not so tight that bearings are cramped and do not turn smoothly and freely.

B. Adjustment, Trouble Shooting and Maintenance

For adjustment, care and lubrication of the bearing head set (S-200), heed the same points mentioned concerning the bottom bracket bearing set in Sec. 6.3.1 B. of this manual.

If bearings are in good working condition and the brace (see Sec. 6.3.10) is properly adjusted, there should be no movement in the steering column base when the handlebar brace is fastened. If play or gaps exist, check to make sure that the pin (S-330) is in its proper place, spring pin C-rings (S-322) are securely fastened, and lock nut (S-340) is tightened. If the problem continues, check and replace bent or worn parts, such as the base pin, steering coupler, steering column or front frame.

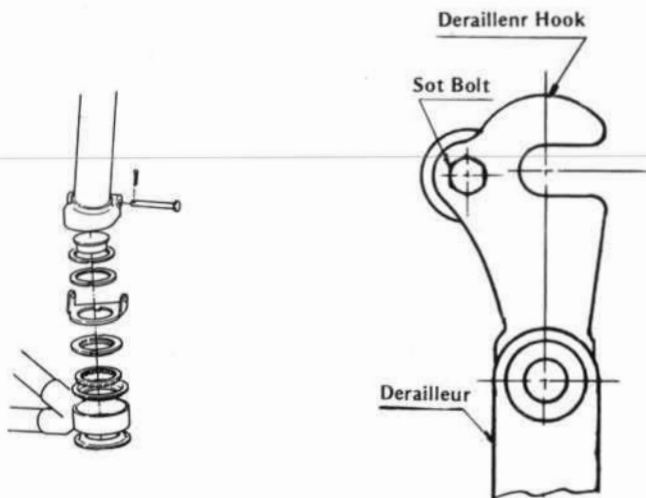

C. Adjustment, Trouble Shooting and Maintenance

Check the chainwheel and free wheel to be sure that they are not bent. If one of the sprockets is bent, replace it or, if the deformation is not too severe, take it to a bicycle dealer to be straightened. If the chainwheel and cog are not in line. If problem persists, there is a possibility that the rear frame is out of alignment and your bicycle should be taken to a dealer for needed servicing. If the derailleur is not aligned, adjust screw A for the small sprocket; screw B for the biggest sprocket.

Always be certain that chain guards are securely fastened to the chainwheel. If the chain guard becomes unevenly spaced with the chainwheel, bent, cracked, or otherwise damaged, replacement of the damaged or worn item is mandatory.

Caution: Chain guards are constructed of plastic and care should be taken so that they are not damaged.

With the chain on, hold the rear wheel and put pressure on the pedals. Note the position of the chain on the teeth. If the teeth are worn excessively, or if the chain is worn and stretched, you will note that the chain rides high on the teeth, rather than lying in the bottom of the tooth spaces. The rear cog can be checked at the same time. If it is determined that the chain or sprockets are worn, or if any teeth or the body of the cog or chainwheel is bent, it is necessary to replace damaged or worn parts. If the above condition is due to excessive wear, the chain and sprockets should be replaced together.

The chain should be cleaned and lubricated at least once every 2 months and more often if adverse weather or riding conditions are often encountered. Oil should be placed between inner and outer plates of the chain. An efficient method of lubricating the chain is to remove it, clean it thoroughly, and lubricate it with SAE 20 oil.

6.3.9. Sprockets and Chain

A. Disassembly

Use a chain bracket to open up the chain for removal. Then, use a driver to loosen the screw behind the hook. One or two turns counter clock wise will suffice. Then use a wrench to loosen the hub nut W301M50. At this point push the derailleur hook backwards & derailleur set can be remove (T830M50).

B. Assembly

Set chain derailleur on smallest sprocket.

6.3.10 Hubs

Inner hub parts are a precise combination of delicate components. If there is any doubt concerning your hubs, take your bike to a professional dealer for servicing. For a 3-speed version, the rear 3-speed gear hub, however, may require some adjustments which can be performed by closely following the steps listed below.

6.3.11 Wheels (Including Spokes and Rims)

A. Disassembly

To remove the front wheel, turn the bicycle upside down, remove the outer nuts and safety washers on both sides of the axle, carefully spread the fork blades out, and remove the wheel.

To remove the rear wheel:

Check the cable adjustment as shown in Sec. 6.3.13. Tighten the cable locknut. Then, without disturbing the locknut position, completely unscrew the adjusting sleeve.

Loosen the rear wheel nut (W301M50) and the cable attachment nut. Using a Philip's screwdriver, unscrew the band brake mounting screw (B311-M). Note the position of the flats on the rear axle in the slots. The rear wheel can now be slide downward and outward from the frame.

Note: It may be necessary to remove one caliper brake shoe (see Sec. 6.3.2) before the tire will move out between the brake shoes.

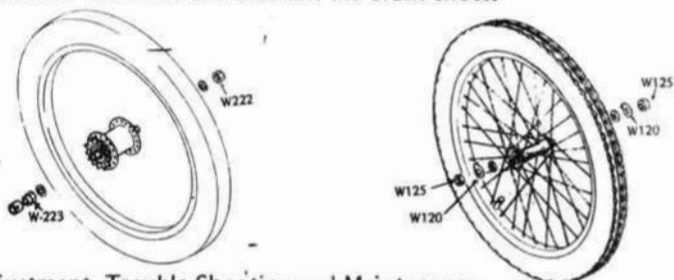

B. Adjustment, Trouble Shooting and Maintenance

When replacing the wheels, be sure that they are carefully centered between the forks and brakes. Be certain that wheel nuts are replaced while all spokes should be adequately tightened. When the gear shift operating cable connector is reassembled, recheck its setting as described in Sec. 6.3.13.

Wheels should be regularly checked for "wobbling" from side to side, and "hop" being out of round or of unequal diameters. This misalignment can be detected best by turning the bicycle upside down, rotating the wheel while using our finger or a pencil placed next to the rim as a guide. Severe misalignment will cause the tire to intermittently rub against the fork, or the rim against the brake shoe.

Warning: Wheel misalignment will lead to grabbing or failure of braking power, and should be corrected at once.

To correct this problem, first check the rim to make sure it is not dented or twisted. If it is, take the wheel to a dealer for specialized repair or replacement.

Uneven spoke tension, or missing, bent or broken spokes, will also cause the wheel to be out of the true. Replace damaged and missing spokes, and with a spoke wrench or small adjustable wrench, turn the nipples of loose spokes clockwise to achieve even tension. Then, if the wheel is off center to the left, tighten the spokes on the right, and loosen the spokes on the left. "Hop" is removed by tightening spokes on both sides of the high area. Final spoke adjustments should be done in small increments.

After this adjustment has been completed, if the wheel remains out of alignment, your bicycle should be taken to a professional dealer for servicing.

6.3.12 Tires and Tubes

A. Disassembly

Remove the wheel as instructed in Sec. 6.3.14. Deflate the tire by pushing in on the pin inside of the tire valve, squeeze the tire to force out as much air as possible. Pinch the tire together all around the rim to break it loose from the rim. Roll the tire off the rim, starting from the opposite side of the tire valve.

Note: If tire removal or installation is too difficult to do with your hands, have it done by a bicycle service shop, as special tools may be required.

Caution: Do not use screwdrivers or other pointed tools which may damage tire, tube or rim.

Before installing the tire, make certain that the rubber rim strip is not damaged and covers all spoke ends. File down any spoke ends projecting out from the spoke nipple. Check the inside of the tire for damage and any object that might puncture the inner tube.

Then, inflate the tube lightly to help keep it in the tire and gradually push one side of the tire onto the rim, again starting from the side opposite the inflation valve. Pull the valve firmly through the valve hole in the rim, and install the other side of the tire starting at the inflation valve. If the valve does not project straight out of the rim hole after the tire is installed, slide the tire around the rim until it is properly positioned. Inflate the tire slightly and then release air to straighten out the inner tube. Then inflate tire as instructed in Sec. 4.4 of this manual.

6.3.13 Mudguards

A. Disassembly—front

Take off the nuts and washers on both sides of the axle, thus freeing the mudguard stay (M120M50). Unscrew the brake and mudguard mounting bolt extruding through the fork crown (S111M50) and remove the front brake and mudguard.

B. Disassembly—rear

Remove the rear wheel as described in Sec. 6.3.14. Then remove the two mounting bolts, thus releasing it from the rear frame.

C. Maintenance:

The mudguards are constructed of plastic, and special care should be taken so as not to break or damage them. They have a fixed form—under no circumstance should this form be altered with pliers or other instruments!

Always be sure that mounting bolts are securely fastened. If the mudguard becomes cracked, chipped or broken, or if it rubs against the tire, replace it so as not to cause a hazard to the tire.

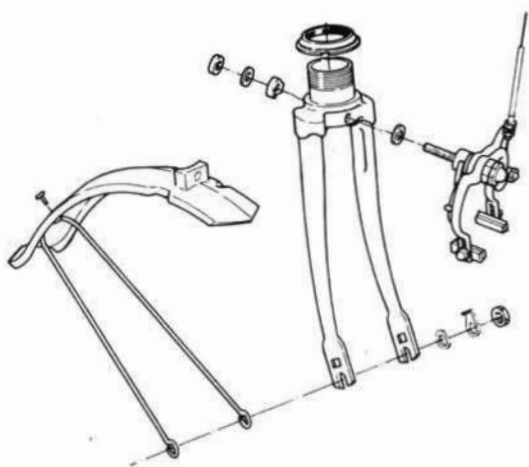

6.3.14 Reflectors and Lamps

A. Disassembly

Front, rear, pedal and wheel reflectors are easily removed by unscrewing their respective mounting bolts.

B. Adjustment and Maintenance

Be certain that mounting bolts are always properly tightened. Often clean your reflectors. If a reflector becomes cracked or otherwise damaged, replace it before riding your bicycle at night.

Although a head lamp may not be included with DAHON Folder, if you ride your bicycle at night, it is strongly recommended—if not required—that an adequate lamp be installed. So that the bicycle can be fully unfolded, this head-lamp must be easily removable. When attached, be certain that it provides ample lighting and is properly adjusted.

Caution: Never adjust reflectors with levers or pointed tools which may crack, scratch and otherwise damage the reflector or other parts of the bicycle.

6.3.15 Dynamo Installation

DAHON INSTALLATION INSTRUCTIONS FOR DYNAMO, LAMP SET

The following instructions are in addition to the instructions furnished in the box containing the Dynamo, Lamp Set.

1. Remove the cap nut from the front brake axel shaft. Install the headlamp bracket support over the axel shaft and replace the cap nut. The bracket support can be bent to position the headlamp as desired. (See diagram)
2. The rear lamp should be installed on the left seatstay tube near the rear hub. (See diagram)
3. The Dynamo unit should be installed on the left seatstay tube just ahead and above the rear lamp location. (See diagram)
- 3a. The location of the Dynamo on the seatstay should be such that permits the rotating end of the Dynamo to turn against the approximate center of the tire sidewall when in "down" position. When in the "up" position, the rotating end of the Dynamo should not be in contact with the tire.
- 3b. The angle of the Dynamo should be fixed at a point permitting the rotating end of the Dynamo to turn smoothly on the same line of rotation as the tire.

NOTE: After installation, fold the bike to make sure that there is no interference when folded.

4. After installation of the Headlamp, Dynamo and Rear Lamp, run the wires as follows:
 - 4a. The Headlamp wire should be placed thru the bracket support then led around the steering bearing housing leaving enough slack to permit turning the handlebar without pulling the wire tight. The wire should be wrapped around the front frame upper tube at least two rotations to assure some slack remains, then continued to reach the Dynamo. NOTE: Be sure and leave enough slack at the frame hinges so the bike can be folded without pulling the wire. Remove excess wire, then attach to the Dynamo contact per the instructions included with the Dynamo.
 - 4b. The Rear Lamp wire should be wrapped once around the seatstay tube to avoid possible entanglement. Remove excess wire, then attach to the Dynamo contact per the instructions included.
5. To check operation, simply position the Dynamo in the "down" position so the rotating end is in contact with the tire, then rotate the wheel. Both lamps should be "on" while the wheel is rotating. If not, check the wiring and their attachment to the Dynamo.

NOTE: This Dynamo, Lamp Set is a universal model and not specifically manufactured for any particular bike. Therefore, certain brackets must be reversed, or slightly altered to permit proper installation.

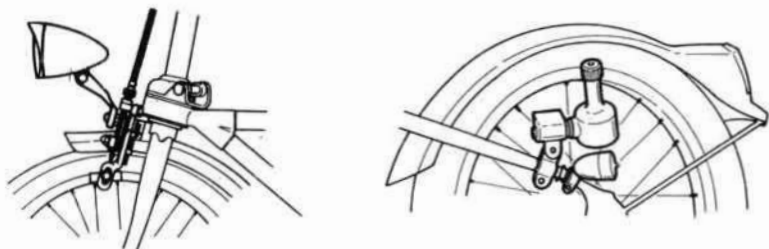

6.3.16 Caster Wheel (Third Wheel)

A. Disassembly—

Unscrew the two elbow assembly mounting bolts (U-320 and U-340), and remove the elbow assembly. Take out the pin (U-120) by first removing the spring clip retainer (U-130) and tapping it out. To remove the caster wheel (U-210), loosen the 4 screws (U-220) which mount it to the caster wheel bracket (U-110).

B. Trouble Shooting and Maintenance

The caster wheel is made of 3 separate components. Cracked, bent, broken or excessively worn components demand replacement. If bolt or screws do not tighten properly, or if the pin is bent or spring pin damaged, replace the necessary fasteners. Always use new mounting screws (U-220) when replacing the caster wheel (U-210). Replace all mounting screws (U-220) together; be careful not to overtighten them, thus stripping out the holes in the bracket (U-110) and causing replacement of this piece.

The elbow assembly will not function properly if it is bent. Try to straighten it out by hand. If this does not work, replace the assembly.

Caution: Failure to raise the caster wheel before riding, or forceful impact against the caster wheel assembly whether in its up or down position, may cause severe damage to the caster wheel assembly.



7 SPECIFICATIONS

BICYCLE	Unfolded size 52-1/2" L X 19" W X 40" H max Folded size 27" L X 9-1/2" W X 18" H Weight 28 pounds Getaway-III, & V. 26 pounds Getaway-I.
FRAME	Hardened steel tubing
SADDLE	Comfortable, padded, vinyl top saddle.
WHEEL	Rim 16" X 1.75" Tire and Tubes 16" X 1.75", tire pressure 45 psi Spoke 14g Front Hub: extra narrow, small flanged, 28 holes Rear Hub: 28 holes
DRIVE	Crank 6-1/2" long One-piece with removable R.H. pedal.
TRAIN	Chain Wheel 3/32" X 52T (Getaway-V) 1/8" X 52T (Getaway-I & III)
CHAIN	1/2" X 3/32" X 51 links (for Getaway-V specially chamferred) 1/2" X 1/8" X 47 links (for Getaway-III)
GEAR	Rear Mechanism Shimano derailleur (Getaway-V) Sturmey Archer 3 speed Hub, 13T Hub Cog (Getaway-III)
GEAR NUMBERS	52" Getaway I 41" - 77" Getaway III 52" - 92" Getaway V
PEDALS	Tough engineering plastic with amber reflectors.

U. S. and international patents. U. S. and international patents pending.

FOLDERS E-1

- A . CRANK AXLE ASSY
- B . BRAKE SYSTEM
- C . CRANK SYSTEM
- F . FRAME
- H . HANDLEBAR SYSTEM
- M . MUDGUARD
- P . SEAT POST SYSTEM
- R . REFLECTORS
- S . STEERING SYSTEM
- T . TRANSMISSION SYSTEM
- U . CASTER WHEEL ASS'Y.
- W . WHEELS

31

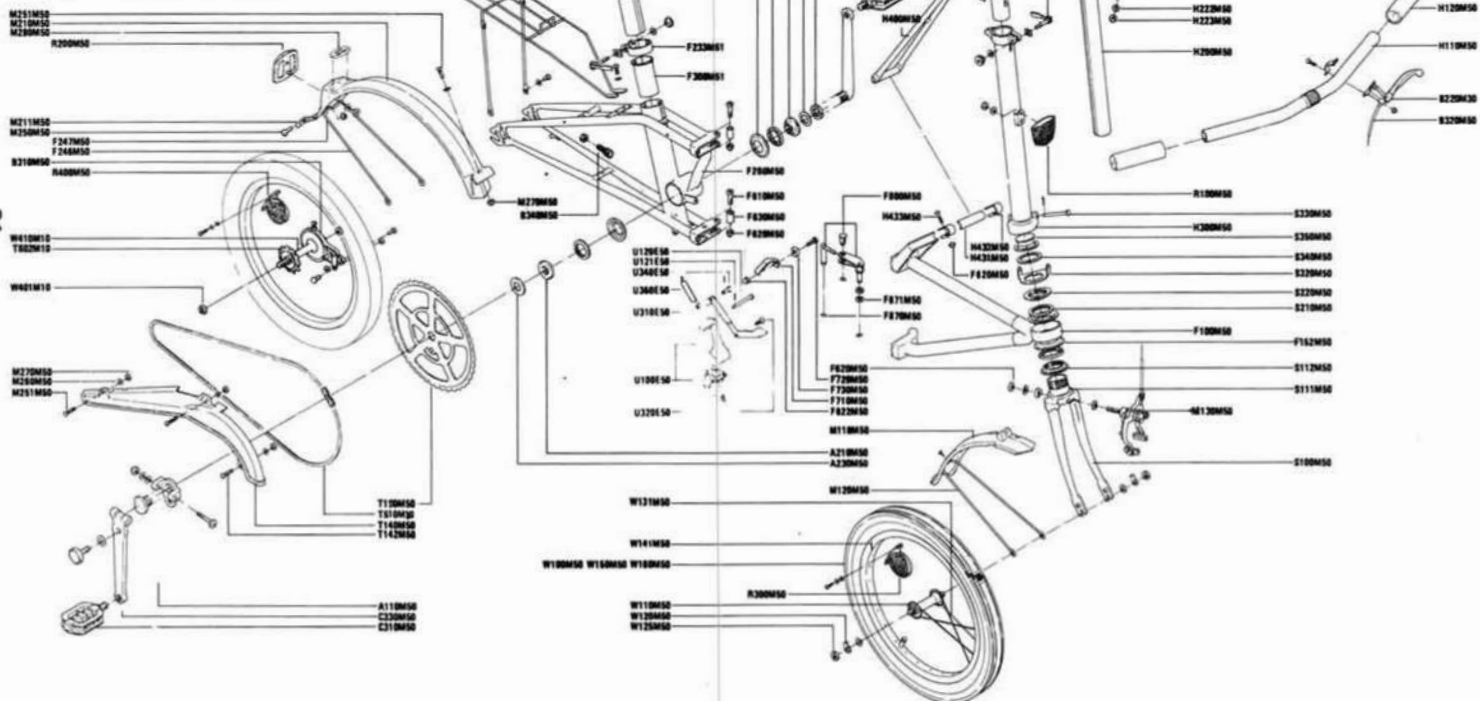

8.1 Parts List :

A.	Crank Axle Ass'y	H.	Handlebar System	S.	Steering System
B.	Brake System	M.	Mudguard	T.	Transmission System
C.	Crank System	P.	Seat Post System	U.	Caster Wheel Ass'y
F.	Frame	R.	Reflectors and Lamp		
A210M50	1 bearing race(R)	F710M50	1 latch spring	P311M51	1 mid seat post
A220M50	2 bearing	F622M50	1 nylon nut	P312M51	1 upper clamp band
A230M50	1 chain wheel washer(RH)	F720M50	1 cap head screw	P330M51	1 upper bushing
A240M50	2 bearing caps	F730M50	1 curved washer	R100M50	1 front reflector
A250M50	1 bearing race (L)	F800M50	1 frame latch ass'y	R200M50	1 rear reflector
A260M50	1 washer(LH)	F870M50	2 C ring	R300M50	1 front wheel reflector
A270M50	1 lock nut	F871M50	2 washer	R400M50	1 rear wheel reflector
B110E50	1 front brake	H110M50	1 handlebar	S100M50	1 fork ass'y
B120E50	1 front brake lever	H130E50	2 handle grip	S112M50	1 insert
B130E50	1 front brake cable	H200M50	1 handle stem ass'y	S210M50	2 bearing
B220M30	1 lever	H221M50	1 bolt	S220M50	1 bearing adjust nut
B310M50	1 rear band brake	H222M50	1 spring washer	S320M50	1 steering coupler
B320M50	1 rear brake cable	H223M50	1 nut	S330M50	1 pin
B340M50	1 adjusting barrel	H230M50	1 handle lug plug	S340M50	2 lock nut
C110E50	1 crank(R)	H300M50	handle post ass'y	S350M50	1 fork crown plug
C111E50	1 insert	H320M50	handle post bushing	T110M50	1 chain wheel
C113E50	1 thumb bolt	H331M50	1 quick release screw A	T140M50	1 chain cover plastic
C121E50	1 crank pin	H332M50	2 quick release screw B	T142M50	1 bolt
C122E50	1 nylon nut	H333M50	3 square washer	T510M10	1 chain
C123E50	1 nylon washer	H334M50	3 adjusting nut	T602M10	1 16T free wheel
F871M50	2 washer	H335M50	3 washer	U100E50	1 caster wheel ass'y
C130E51	1 crank support	H340M51	1 a-frame fast ass'y	U120E50	1 pin
C310M50	1 pedal(R)	H343M50	1 knob	U121E50	2 split pin
C320M50	1 pedal(L)	H347M50	1 label	U310E50	1 elbow
F100M50	1 front frame ass'y	H400M50	1 a-frame ass'y	U320E50	1 screw
F152M50	2 bearing race	H431M50	1 half sleeve	U340E50	1 pin
F200M50	1 rear frame ass'y	H432M50	2 half sleeve clamp band	U360E50	1 elbow spring
F233M51	1 lower clamp band	H433M50	2 cap head screw	W100M50	1 front wheel ass'y
F246M50	1 rear mudguard stay	F620M50	2 nylon nut	W110M50	1 front hub ass'y
F247M50	1 mudguard stay mounting	M110M50	1 front mudguard	W120M50	2 washer
F300M51	1 lower bushing	M120M50	1 front mudguard stay	W125M50	2 nut
M251M50	3 cap head screw	M210M50	1 rear mudguard	W131M50	28 spoke (front wheel)
M260M50	5 washer	M211M50	1 rear mudguard support	W141M50	2 rim
M270M50	5 nylon nut	M250M50	1 flat hrad screw	W150M50	2 inner tube (U.S.A. type)
F610M50	2 lug pin	M280M50	1 rear mudguard logo	W160M50	2 tire
F620M50	2 nylon nut	P110E50	1 spring saddle	W401M10	2 hub nut
F630M50	2 lug pin bush	P210M51	1 top seat post	W410M10	1 1-speed hub
				X900	1 carrier

FOLDERS E-3

- A . CRANK AXLE ASS'Y
- B . BRAKE SYSTEM
- C . CRANK SYSTEM
- F . FRAME
- H . HANDLEBAR SYSTEM
- M . MUDGUARD
- P . SEAT POST SYSTEM
- R . REFLECTORS
- S . STEERING SYSTEM
- T . TRANSMISSION SYSTEM
- U . CASTER WHEEL ASS'Y
- W . WHEELS

- M211M50
- M210M50
- M20M50
- R20M50

- M211M50
- M20M50
- F247M50
- F248M50
- W222M30
- R40M50

- W210M30
- T001M30

- W222M30
- T20M30
- T20M30

- M270M50
- M260M50
- M251M50

- C1210 50
- C1220 50
- F871M50

- C1230 50
- C1130 50

- C1300 50
- C1200 50
- C1100 50
- C1000 50

- P212M51
- K320M50
- K333M50
- K327M50

- P330M51

- P210M51
- X300M50

- U1200 50
- U1210 50
- U3400 50
- U3600 50
- U3100 50
- U1000 50
- U2200 50

- F230M50
- F230M50
- F230M50

- W131M50
- W141M50
- W100M50
- W130M50
- W100M50
- W125M50

- W110M50
- W120M50
- W130M50

- P210M51
- A240M50
- A220M50
- A250M50
- A260M50
- A270M50

- C320M50
- H400M50

- F810M50
- F820M50
- F820M50

- F871M50
- F870M50

- F720M50
- F730M50
- F710M50
- F820M50

- M110M50
- A210M50
- A230M50

- W130M50

- R300M50

- H347M50
- H343M50
- H340M50

- H400M50

- F800M50
- H423M50
- H423M50
- H421M50
- F820M50

- F871M50
- F870M50

- M110M50
- A210M50
- A230M50

- W130M50

- R300M50

- H320M50
- H331M50
- H330M50

- H321M50
- H222M50
- H223M50
- H200M50

- H100M50
- H200M50

- S330M50
- S350M50
- S340M50
- S220M50
- S230M50
- S210M50

- F100M50
- F162M50
- S112M50
- S111M50

- S100M50

- T710M30
- T720M30

- H1300 50
- H110M50
- S220M30
- S230M30
- S1300 50
- S1200 50

- H100M50

- S330M50
- S350M50
- S340M50
- S220M50
- S230M50
- S210M50

- F100M50
- F162M50
- S112M50
- S111M50

- S100M50

8.2 Parts List :

	A.	Crank Axle Ass'y	B.	Brake System	C.	Crank System	F.	Frame	H.	Handlebar System	M.	Mudguard	P.	Seat Post System	R.	Reflectors and Lamp	S.	Steering System	T.	Transmission System	U.	Caster Wheel Ass'y
A210M50	1	bearing race(R)	F870M50	2	C ring	S100M50	1	frok ass'y														
A220M50	2	bearing	F871M50	2	washer	S111M50	1	fork crown														
A230M50	1	chain wheel washer(RH)	H110M50	1	handlebar	S112M50	1	insert														
A240M50	2	bearing caps	H130E50	2	handle grip	S210M50	2	bearing														
A250M50	1	bearing race (L)	H200M50	1	handle stem ass'y	S220M50	1	bearing adjust nut														
A260M50	1	washer (LH)	H221M50	1	bolt	S320M50	1	steering coupler														
A270M50	1	lock nut	H222M50	1	spring washer	S330M50	1	pin														
B110E50	1	front brake	H223M50	1	nut	S332M50	1	C ring														
B120E50	1	front brake lever	H230M50	1	handle lug plug	S340M50	2	lock nut														
B130E50	1	front brake cable	H300M50	1	handle post ass'y	S350M50	1	fork crown plug														
R220M30	1	lever	H320M50	1	handle post bushing	T110M50	1	chain wheel														
C110E50	1	crank (R)	H331M50	1	quick release screw A	T140M50	1	chain cover plastic														
C113E50	1	thumb bolt	H332M50	2	quick release screw B	T142M50	1	bolt														
C120E50	1	two piece axle	H333M50	3	square washer	T510M10	1	chain														
C121E50	1	crank pin	H334M50	3	adjusting nut	T601M50	1	13T free wheel														
C122E50	1	nylon nut	H335M50	3	washer	T710M30	1	trigar gear control lever														
C123E50	1	nylon washer	H340M51	1	a-frame fast ass'y	T720M30	1	3-speed control cable														
F871M50	2	washer	H343M50	1	knob	T730M30	1	indicator coupling														
C130E51	1	crank support	H347M50	1	label	T740M30	1	indicator coupling protector														
C310M50	1	pedal(R)	H400M50	1	a-frame ass'y	U100E50	1	caster wheel ass'y														
C320M50	1	pedal(L)	H431M50	1	half sleeve	U120E50	1	pin														
F100M50	1	front frame ass'y	H432M50	2	half sleeve clamp band	U121E50	2	split pin														
F152M50	2	bearing race	H433M50	2	cap head screw	U310E50	1	elbow														
F200M50	1	rear frame ass'y	F620M50	2	nylon nut	U320E50	1	screw														
F233M51	1	lower clamp band	M110M50	1	front mudguard	U340E50	1	pin														
F246M50	1	rear mudguard stay	M120M50	1	front mudguard stay	U360E50	1	elbow spring														
F247M50	1	mudguard stay mounting	M210M50	1	rear mudguard	W100M50	1	front wheel ass'y														
F300M51	1	lower bushing	M211M50	1	rear mudguard support	W110M50	1	front hub ass'y														
M251M50	3	cap head screw	M250M50	1	flat head screw	W120M50	2	washer														
M260M50	5	washer	M282M50	1	rear mudguard logo	W125M50	2	nut														
M270M50	5	nylon nut	P100M50	1	saddle	W131M50	28	spoke (front wheel)														
F610M50	2	lug pin	P210M51	1	top seat post	W141M50	2	rim														
F620M50	2	nylon nut	P311M51	1	mid seat post	W150M50	2	inner tube (U.S.A. type)														
F630M50	2	lug pin bush	P312M51	1	upper clamp band	W160M50	2	tire														
F710M50	1	latch spring	P330M51	1	upper bushing	W210M30	1	3-S hub														
F622M50	1	nylon nut	R100M50	1	front reflector	W222M30	1	left nut														
F720M50	1	cap head screw	R200M50	1	rear reflector	W223M30	1	right nut														
F730M50	1	curved washer	R300M50	1	front wheel reflector	X990M50	1	carrier														
F800M50	1	frame latch ass'y	R400M50	1	rear wheel reflector																	

FOLDERS E-5

- A. CRANK AXLE ASS'Y
- B. BRAKE SYSTEM
- C. CRANK SYSTEM
- F. FRAME
- H. HANDLEBAR SYSTEM
- M. MUDGUARD
- P. SEAT POST SYSTEM
- R. REFLECTORS
- S. STEERING SYSTEM
- T. TRANSMISSION SYSTEM
- U. CASTER WHEEL ASS'Y
- W. WHEELS

35

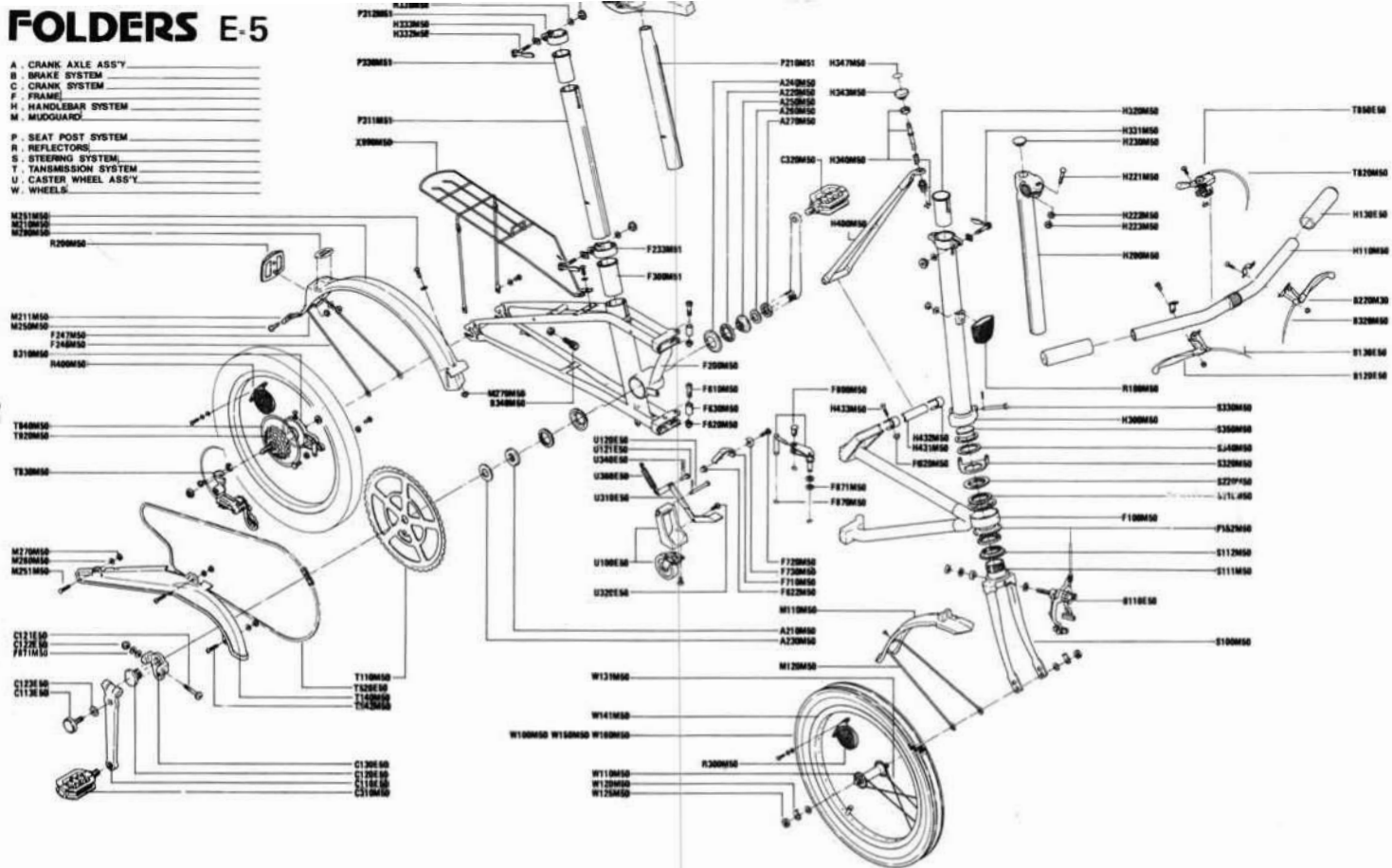

8.3 Parts List :

A	Crank Axle Ass'y	H	Handlebar System	S	Steering System
B	Brake System	M	Mudguard	T	Transmission System
C	Crank System	P	Seat Post System	U	Caster Wheel Ass'y
F	Frame	R	Reflector and Lamp		
A210M50	1 bearing race(R)	F620M50	2 nylon nut	M250M50	1 flat hrad screw
A220M50	2 bearing	F630M50	2 lug pin bush	M280M50	1 rear mudguard logo
A230M50	1 chain wheel washer(RH)	F710M50	1 latch spring	P110E50	1 spring saddle
A240M50	2 bearing caps	F622M50	1 nylon nut	P210M51	1 top seat post
A250M50	1 bearing race (L)	F720M50	1 cap head screw	P311M51	1 mid seat post
A260M50	1 washer (LH)	F730M50	1 curved washer	P312M51	1 upper clamp band
A270M50	1 lock nut	F800M50	1 frame latch ass'y	P330M51	1 upper bushing
B110E50	1 front brake	F870M50	2 C ring	R100M50	1 front reflector
B120E50	1 front brake lever	F871M50	2 washer	R200M50	1 rear reflector
B130E50	1 front brake cable	H110M50	1 handlebar	R300M50	1 front wheel reflector
B220M30	1 lever	H130E50	2 handle grip	R400M50	1 rear wheel reflector
B310M50	1 rear band brake	H200M50	1 handle stem ass'y	S100M50	1 fork ass'y
B320M50	1 rear brake cable	H221M50	1 bolt	S100M50P	1 paint fork ass'y
B310M50	1 adjusting barrel	H222M50	1 spring washer	S112M50	1 insert
C110E50	1 crank (R)	H223M50	1 nut	S210M50	2 bearing
C113E50	1 thumb bolt	H230M50	1 handle lug plug	S220M50	1 bearing adjust nut
C120E50	1 two piece axle	H300M50	1 handle post ass'y	S320M50	1 steering coupler
C121E50	1 crank pin	H320M50	1 handle post bushing	S330M50	1 pin
C122E50	1 nylon nut	H331M50	1 quick release screw A	S340M50	2 lock nut
C123E50	1 nylon washer	H332M50	2 quick release screw B	S350M50	1 fork crown plug
F871M50	2 washer	H333M50	3 square washer	T110M50	1 chain wheel
C130E51	1 crank support	H334M50	3 adjusting nut	T140M50	1 chain cover plastic
C310M50	1 pedal (R)	H335M50	3 washer	T142M50	1 bolt
C320M50	1 pedal (L)	H340M51	1 a-frame fast ass'y	T520E50	1 chain
F100M50	1 front frame ass'y	H343M50	1 knob	T820M50	1 gear cable
F152M50	2 bearing race	H347M50	1 label	T830M50	1 rear derailleur
F200M50	1 rear frame ass'y	H400M50	1 a-frame ass'y	T840M50	1 5-speed gears cover
F233M51	1 lower clamp band	H431M50	1 half sleeve	T850E50	1 gear lever
F246M50	1 rear mudguard stay	H432M50	2 half sleeve clamp band	T920M50	1 9T 5-speed gear ass'y
F247M50	1 mudguard stay mounting	H433M50	2 cap head screw	U100E50	1 caster wheel ass'y
F300M51	1 lower bushing	F620M50	2 nylon nut	U120E50	1 pin
M251M50	3 cap head screw	M110M50	1 front mudguard	U121E50	2 split pin
M260M50	5 washer	M120M50	1 front mudguard stay	U310E50	1 elbow
M270M50	5 nylon nut	M210M50	1 rear mudguard	U320E50	1 screw
F610M50	2 lug pin	M211M50	1 rear mudguard support	U340E50	1 pin