

SEARS

OWNER'S MANUAL

Model No.
200.71440

SEARS

40/2,

200^{amp}
engine starter
for (3 WpA Bopurti)



**40/2 AMP
MANUAL BATTERY
CHARGER**

**200 AMP
ENGINE STARTER**

CAUTION:

**Read and Follow All Safety
Rules and Operating instructions
Before Every Use of this Product.**

Sears, Roebuck and Co., Hoffman Estates, IL 60179 U.S.A.

Table Of Contents

Warranty.....	1	Using Your Battery Charger.....	7
Important Safety Instructions.....	2	Setting the controls.....	7
Parts.....	3	Charging your battery.....	8
Before Using Your Battery Charger.....	4	Calculating charge time.....	10
Assembling your charger.....	4	Using the engine start feature.....	11
Plugging it in.....	5	Maintenance and care.....	11
Using an extension cord.....	6	Troubleshooting.....	12
Preparing your battery to be charged.....	6		

Please read this Owner's Manual before using your Battery Charger

The Sears model 200.71440, Manual Battery Charger/Engine Starter, offers a wide range of features to accommodate the needs for home or commercial use. This manual will show you how to use your charger safely and effectively. Please read and follow these instructions and precautions carefully.

Warranty

FULL THREE-YEAR WARRANTY

If, within three years from the date of purchase this battery charger fails due to a defect in materials or workmanship, simply RETURN IT TO THE NEAREST SEARS STORE IN THE UNITED STATES, and Sears will repair or replace it, free of charge.

This warranty gives you specific legal rights, and you may also have other rights which vary from state to state.

Sears, Roebuck and Co., Dept 81 TWA,
Hoffman Estates, IL 60179

Important Safety Instructions

- SAVE THESE INSTRUCTIONS -

Warning

To reduce the risk of explosion, explosive gases, or injury while using your battery charger, follow the precautions listed below:

- Read all instructions and cautions printed on the battery charger, battery, and vehicle or equipment using battery.
- ' Use charger only on lead-acid type rechargeable batteries, such as those used in cars, trucks, tractors, airplanes, vans, RV's, trolling motors, etc. This charger is not intended to supply power to a low voltage electrical system other than in an automotive application.
- Use only attachments recommended or sold by manufacturer. The use of attachments not recommended by the manufacturer may result in fire, electric shock, or injury.
- Do not disassemble charger. Take it to a qualified service professional if service or repair is required. Incorrect assembly may result in fire or electrical shock.
- To reduce risk of electrical shock, unplug the charger from the outlet before attempting any maintenance or cleaning.
- Always charge battery in a well ventilated area.

Help us help you

Remember:

- Place charger as far away from battery being charged as the charger cables will permit.
- Do not expose charger to rain or snow.
- Never charge a frozen battery. If battery fluid (electrolyte) becomes frozen, bring battery into a warm area to thaw before you begin charging.
- Never allow battery acid to drip on charger when reading specific gravity or filling battery.
- Never set a battery on top of the charger.
- Never place charger directly above battery being charged. The gases from the battery will corrode and damage the charger.
- Never use charger for charging dry-cell batteries that are commonly used with home appliances. These batteries may burst and cause personal injury.
- ' Never touch the battery clamps together when the charger is energized.
- ' Never operate charger if it has received a hard blow, been dropped, or otherwise damaged. Take it to a qualified professional for inspection and repair.
- ' Be sure to position the charger power cord to prevent it from being stepped on, tripped over, or damaged.
- Never pull out the plug by the cord when unplugging the charger. Pulling on the cord may cause damage to the cord or the plug.
 - Do not operate the charger if it has a damaged power cord or plug. Have the cord replaced.

Personal Safety Precautions

For your own personal safety, please follow the following precautions:

- Wear complete eye and clothing protection when working with lead-acid batteries.
- Be sure that someone is within range of your voice to come to your aid if needed while you work with or are near a lead-acid battery.
- * Have plenty of fresh water and soap nearby for use in case battery acid contacts your eyes, skin, or clothing. If this happens, wash immediately with soap and water. Then get medical attention.
- * Avoid touching your eyes while working with a battery. Acid particles (corrosion) may get into your eyes, if this occurs, flush eyes immediately with running cold water for at least 10 minutes. Then immediately get medical attention.
- ' Remove all personal metal items from your body, such as rings, bracelets, necklaces, and watches while working with a lead-acid battery. A battery can produce a short circuit current high enough to weld a ring (or the like) to metal, causing a severe burn.
- Take care not to drop any metal tool or metal object onto the battery. This may spark or short circuit the battery or another electrical device that may cause an explosion.
- Always operate your battery charger in an open, well ventilated area.
- Never smoke or allow a spark or flame in the vicinity of the battery or engine. Batteries generate explosive gases.
- Neutralize any acid spills thoroughly with baking soda before attempting to clean up.

Parts

This section shows an illustration of your battery charger. Use it to become familiar with where all the parts are located, and what they look like.

Replacement Parts List Sears 71440		
item	Description	Part Number
1	Handle	3599000286
2	Negative (BLK) cable w/clamps	3899000396
3	Positive (RED) cable w/clamps	3899000410
4	Power Cord	90026096
5	Circuit Breaker Asm	3999000057
6	Rectifier Assembly	2299000614
7	Transformer	93026365
8	Owner's Manual (not shown)	0000000516
9	Wheel	0099000080
10	Hub Cap	5200000008
11	Axle	0099000060
12	Axle mtg, bracket	1199004366
13	Mounting Foot	1199003352
14	Rocker Switch 3 pos.	0499000052
15	Ammeter	5399100097
16	Rocker Switch 2 pos.	0499000050

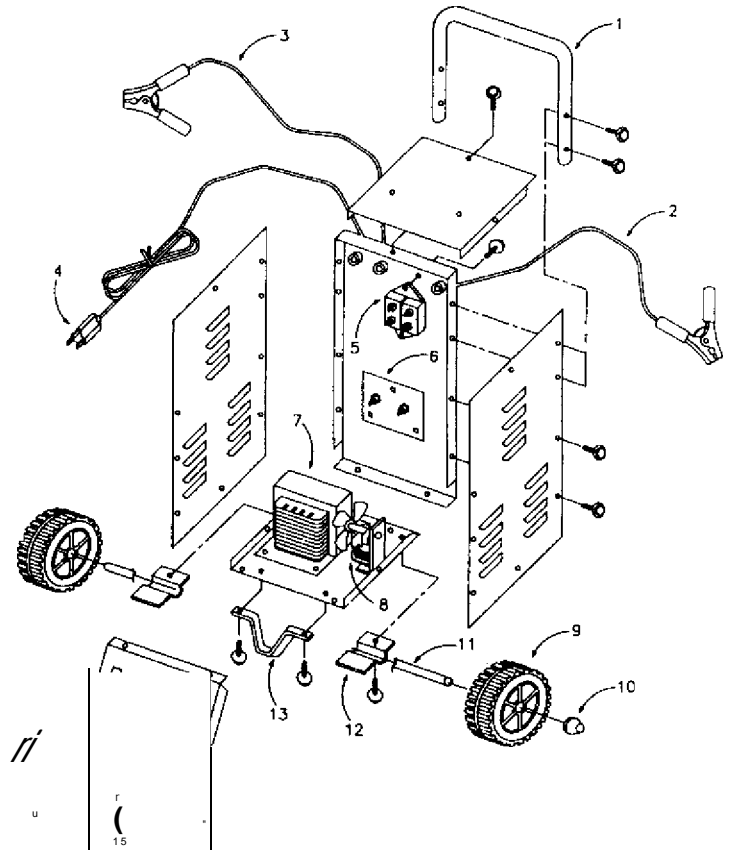

Wiring diagram

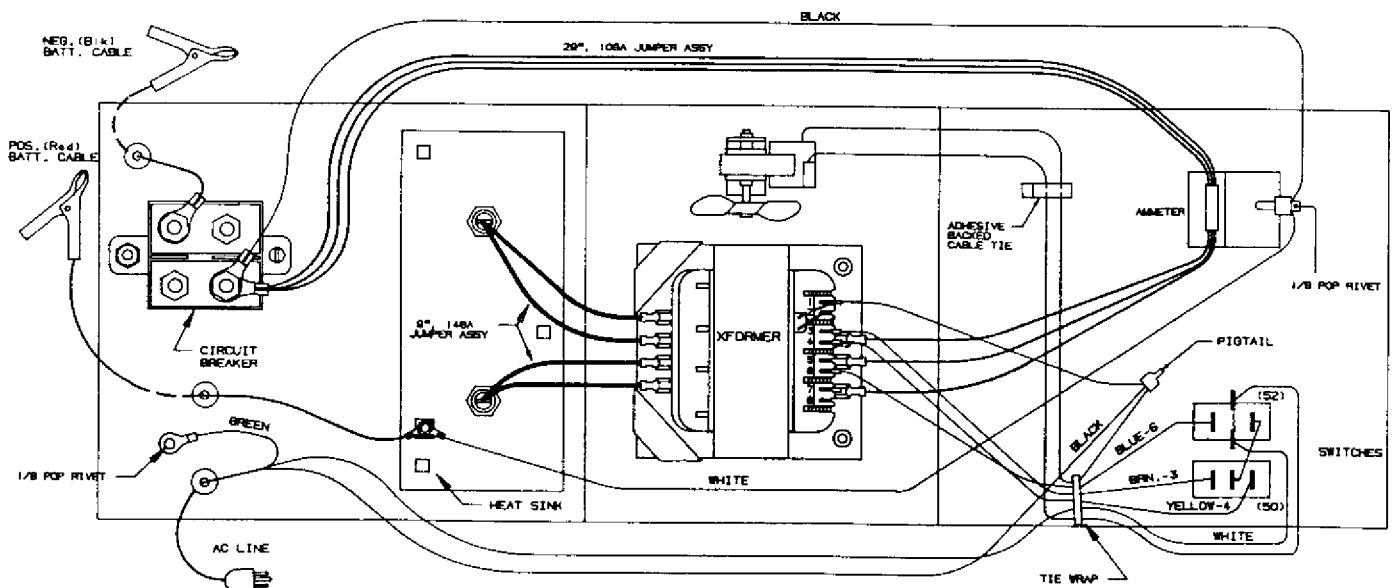

Before Using Your Battery Charger

It is important to prepare your charger for use. This section will tell you how to assemble the charger, ground and connect the power cord, and prepare to charge a battery.

Assembling your charger

It is important to fully assemble your charger before use. Follow these instructions for easy assembly.

PARTS:

Two 10-32 thread cutting screws

Two 1/4-20 thread cutting screws

Two wheels

One axle

Two axle caps

Two axle brackets

One handle

One mounting foot

TOOLS NEEDED:

3/8" wrench
(for mounting foot)

5/16" wrench
(for wheels)

Hammer

Phillips screwdriver

To attach the axle assembly:

1. Remove charger from packing materials and place upside down on a flat surface. Attach mounting foot and secure with the two 1/4-20 thread cutting screws.

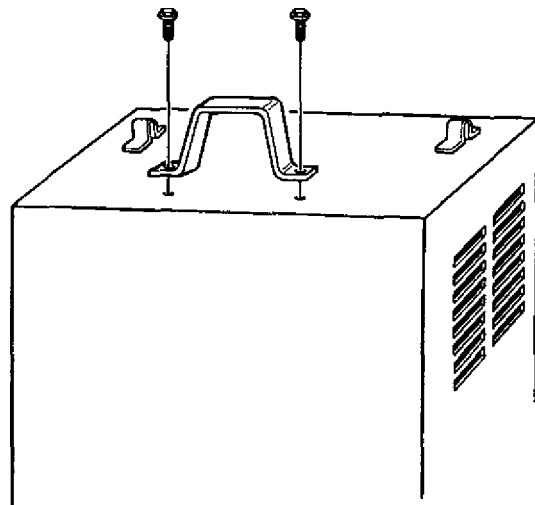

2. Hold axle upright on floor or work surface. Then, using a hammer, tap one of the plastic hubs onto the top end of the axle. Be sure to tap the hub on straight. Slide both wheels onto the axle with the hubs facing inward.



continued on next page

3. Tap the other axle cap onto the opposite end of the axle and place the axle assembly onto the bottom of the charger. Place one end of the bracket into slot, then place the axle assembly under each bracket. Fasten the other side of the brackets using the two 10-32 screws provided.

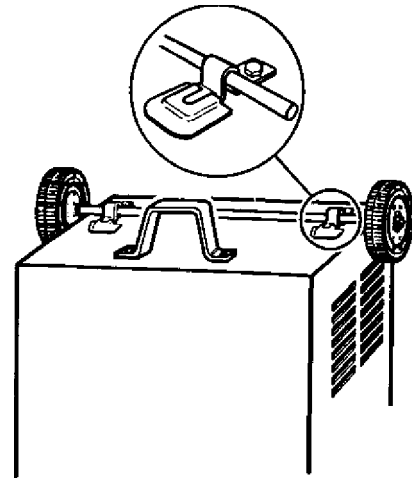

To attach the handle:

Turn the charger right side up onto its foot and wheels. Remove the two top screws from each side of the charger and align with the screw holes on the handle. Attach the handle using the same screws.

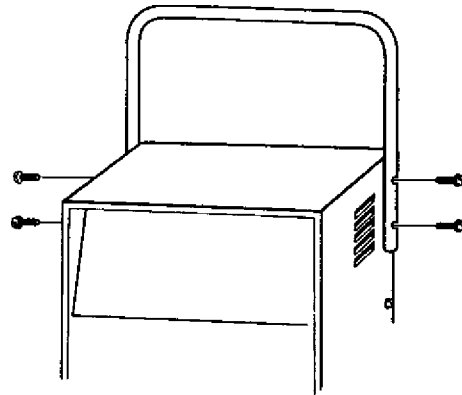

Plugging it in

Warning

Electrical Shock Hazard

Be sure that power cord fits properly into outlet. If not, have a qualified technician install a proper outlet. Never alter the AC cord or plug provided. Improper connection can result in electrical shock.

Your charger should be grounded to reduce the risk of electrical shock.

Your charger is equipped with an electrical cord that has an equipment grounding conductor and a grounding plug designed to be used on a 120 volt circuit. The plug must be plugged into an outlet that has been properly installed and grounded in accordance with all local codes and ordinances.

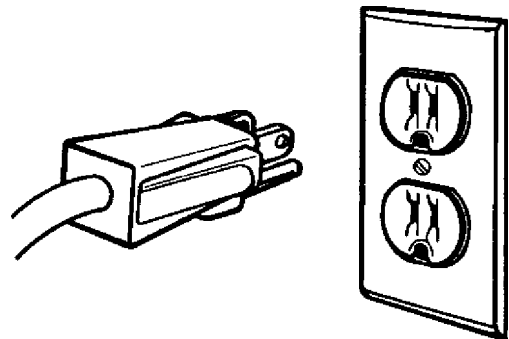

A TEMPORARY adapter may be used to connect the charger to a two-pole outlet if a properly grounded outlet is not available. Use the adapter ONLY until a properly grounded outlet can be installed by a qualified electrician.

DANGER: Before using an adapter as illustrated, be certain that the center screw of the outlet plate is grounded. The green colored grounding clip of the adapter must be attached by a screw to a properly grounded outlet. If unsure whether outlet is properly grounded, contact a professional electrician. If necessary, replace the original outlet cover screw with a longer one that will secure the grounding clip to the outlet cover and make a ground connection to the grounded outlet.

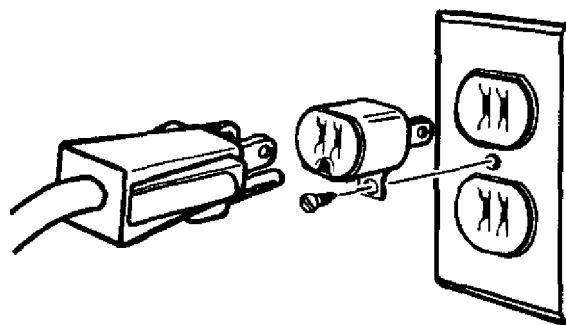

Using an extension cord

The use of an extension cord is not recommended. If you must use an extension cord, please make sure that you follow these guidelines:

- Make sure the pins on the plug of the extension cord are the same number, size, and shape as those of the plug on the charger.
- Use only 3-Conductor (grounded) extension cord when necessary.
- Check that the extension cord is properly wired and in good electrical condition.
- Use the recommended minimum AWG (American Wire Gauge) to be sure that wire size is large enough for the rating of the charger.

MINIMUM RECOMMENDED		EXTENSION CORD		
Length of Cord, In Feet	25	50	100	150
AWG* Size of Cord	18	14	12	10

*AWG=American Wire Gauge

Preparing your battery to be charged

It is important that you read and follow these guidelines while you are preparing to charge your battery.

- Make sure that you have a 12 volt lead-acid battery. Clean the battery terminals. Be careful to keep corrosion from getting in or around your eyes.
- If you have a battery with removable cell caps, if required, add distilled water to each cell until the battery acid reaches the level indicated by the manufacturer. This will help purge excessive gases from the cells. Be careful not to overfill. If you have a sealed battery without cell caps, no action is necessary. Continue to the next step listed below.
- Take time to read all battery manufacturer's specific precautions, such as removing or not removing cell caps while charging, and recommended rates of charge.
- Wear safety glasses. See additional "Personal Safety Precautions" on page 2.
- Be sure that the area around the battery is well ventilated while it is being charged. If ventilation is poor, gas can be manually blown away by using a piece of cardboard or other non-metallic material as a fan.
- If it is necessary to remove the battery from the vehicle to charge it, always remove the grounded terminal from the battery first. A spark may be caused if all accessories in the vehicle are not completely turned off.

NOTE: A marine battery installed in a boat must be removed and charged on shore.

Using Your Battery Charger

To obtain the best results from your battery charger, you must know how to use it properly. This section will tell you how to set the controls. And how you can charge a battery while it is still in the vehicle, or you can remove it and then charge it. Follow the instructions below depending on how you choose to charge your battery.

Setting the controls

All the controls for your charger are located on the front of the unit. Follow these instructions to obtain the accurate charge level for your battery

OUTPUT SELECTOR SWITCHES

Two switches are used to select the rate of charge or function—a 3-position switch on the right, and a 2-position switch to the left of it. Use the 3-position switch to select:

- **2 Amp Trickle Charge** — Use for charging small batteries and warming large batteries. The lower the charge rate, the longer it will take, but the battery is subjected to much less stress.
- **OFF** — Leave the switch in the OFF Position while connecting the charger to the battery and to the AC power outlet,
- **Select** — This setting enables you to select one of the two charge-rate settings offered by the 2-position switch.
 - Use the 40 Amp Charge rate for a fast charge.
 - Use the 200 Amp Engine Start for cranking the engine. Remember that little or no charging has been done by the charger and, unless your trip is quite long, your battery will still need further charging by the vehicle's charging system once the engine starts.

AMMETER

The AMMETER indicates the measured amount of amperes being drawn by the battery. When you first start charging a battery, the reading will be high, with the needle near 40 at the 40 AMP CHARGE rate. As the battery charges, the needle will fall to about 15 to 20 amps, indicating a charged battery.

At the 2 AMP CHARGE rate, you will notice very little needle movement.

When cranking the engine while using the ENGINE START feature, the needle will swing into the Start (red) area of the scale.

40A 12V
CHARGE

2A 12V
CHARGE

OFF

200A 12V
ENGINE
START

L. SELECT

VOLT/AMP SELECTOR

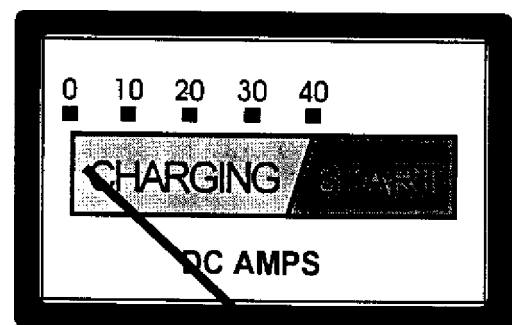

Charging Your Battery

Charging your battery in the vehicle:

1. Arrange the power cord and charging leads carefully in order to avoid damage that could be caused by the hood, door, or moving engine parts.
2. Keep clear of the fan blades, belts, pulleys, and other parts that can cause injury.
3. Check the polarity of the battery posts using the identification marks on the battery case: **POSITIVE** (POS, P, +) and **NEGATIVE** (NEG, N, -).
4. Identify which battery post is ground or connected to the chassis. **THE NEGATIVE POST IS NORMALLY THE ONE THAT IS GROUNDED.**
5. To charge a negative grounded post system: Connect the red (POSITIVE) charger clamp to the ungrounded POSITIVE (POS, P, +) post of the battery. Next, connect the black (NEGATIVE) clamp to a heavy unpainted metal part of the chassis or engine block, away from the battery. Do not connect clamp to carburetor, fuel lines, or sheet metal parts.
To charge a positive grounded post system: Connect the black (NEGATIVE) charger clamp to the ungrounded NEGATIVE (NEG, N, -) post of the battery. Then connect the red (POSITIVE) clamp to a heavy unpainted metal part of the chassis or engine block, away from the battery. Do not connect clamp to carburetor, fuel lines or sheet metal parts.
6. Connect the clamp to the battery post and twist or rock back and forth to make a solid connection. This will help keep the clamps from slipping off the posts and causing sparks.
7. Set your charger's right-hand 3-position selector switch to the OFF position. Then plug the charger's power cord into a grounded AC outlet.
8. Select the desired charge rate. (See "Setting the Controls" on page 7.)
9. The charger will not stop when the battery is fully charged. For this reason it is important to check charging progress frequently. Overcharging can damage a battery, you must monitor and unplug charger when battery is fully charged.
10. When the battery is fully charged, the AMMETER needle will fall to about half the charge rate selected. For specific positions, see the "Ammeter" section of "Setting the Controls" on page 7.
11. When the battery is fully charged, unplug the charger power cord. Next, set the right-hand switch to the OFF position.
12. Standing away from the battery, remove the charger clamp from the chassis first, then from the battery post or terminal,
13. Clean and store the battery charger in a dry location.

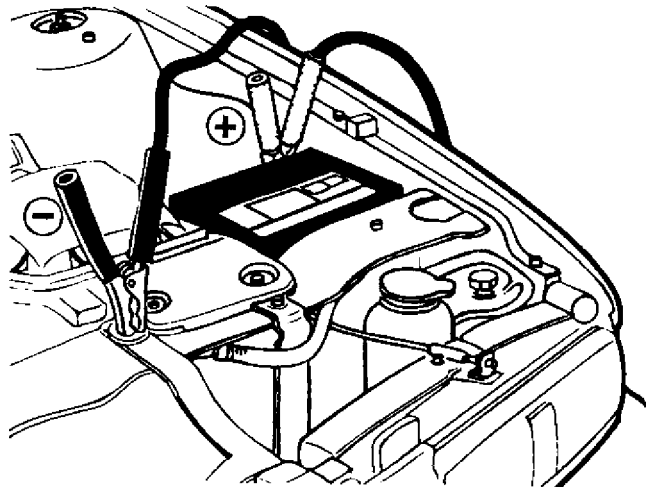

Charging your battery outside the vehicle:

1. Remove the battery from vehicle, making sure to disconnect grounded terminal first with all power turned off to the vehicle.
2. Check the polarity of the battery posts as indicated on the battery case: POSITIVE (POS, P, +) and NEGATIVE (NEG, N, -).
NOTE: On top-post batteries, the positive battery terminal usually has a larger diameter than the negative one.
3. Connect the red (POSITIVE) charger clamp to the POSITIVE post of the battery. Be sure to rock the clip back and forth to make a solid connection.
4. Attach a 6-gauge (AWG) or a 4-gauge (SAE) insulated battery cable of at least 24-inches in length to the NEGATIVE battery post. This cable will provide a safer connection because any arcing and sparking will not occur directly over the battery. (The battery cable is not provided with the charger, but may be purchased at most automotive accessory outlets.)
5. Take the other end of the 6-gauge (AWG) or a 4-gauge (SAE) insulated 24-inch cable and, standing as far away from the battery as possible, connect the black (NEGATIVE) lead to the free end of the cable. Be sure to rock the clamp to make a solid connection, IMPORTANT; Wear safety glasses and face away from the battery while making the final connection.
6. Set your charger's right-hand 3-position selector switch to the OFF position. Then plug the charger's power cord into a grounded AC outlet.
7. Select the desired charge rate. (See "Setting the Controls" on page 7.)
8. The charger will not stop when the battery is fully charged. For this reason it is important to check charging progress frequently. Overcharging can damage a battery, you must monitor and unplug charger when battery is fully charged.
9. When the battery is fully charged, the AMMETER needle will fall to about half the charge rate selected. For specific positions, see the "Ammeter" section of "Setting the Controls" on page 7.
10. When the battery is fully charged, unplug the charger power cord before attempting to disconnect charger clamps.
11. Standing away from the battery, remove the charger leads. Remove the NEGATIVE clamp first, then from the POSITIVE battery post or terminal.
12. Clean and store the battery charger in a dry location.

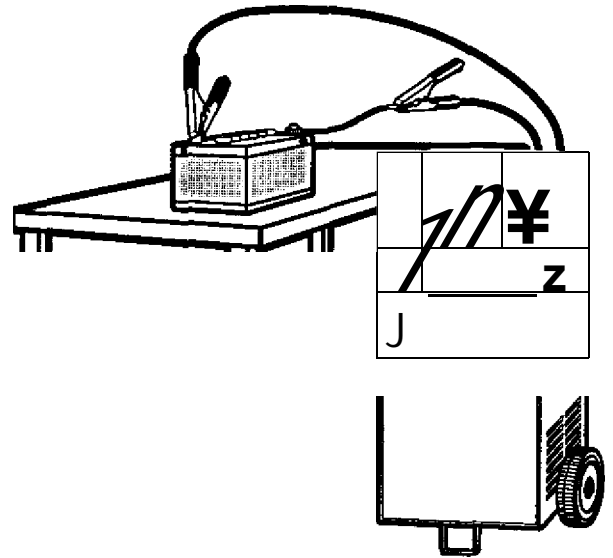

Calculating charge time

The Chart Method

Use the following table to more accurately determine the time it will take to bring a battery to full charge.

First, identify where your battery fits into the chart.

- Small batteries — motorcycles, garden tractors, etc. — are usually rated in Ampere Hours (AH). For example; 6 to 12 AH, or 12 to 32 AH.
- Batteries in cars and smaller trucks are usually rated in Reserve Capacity (RC), Cold-Cranking Amps (CCA), or both.

- Marine, or deep-cycle batteries are usually rated in Reserve Capacity (RC).
- NR means that the charger setting is NOT RECOMMENDED.

Find your battery's rating on the following chart and note the charge time given for each charger setting. The times given are for batteries with a 50-percent charge. Add more time for totally discharged batteries.

BATTERY SIZE/RATING			CHARGE RATE/CHARGING TIME - HOURS	
			2 AMP	40 AMP
SMALL BATTERIES	Motorcycle, garden tractor, etc.	6-12AH	2-4	NR
		12-32 AH	4-10	NR
CAR^RUCKS	200-315 CCA	40 - 60 RC	11-14	1/2-3/4
	315-550 CCA	60 - 85 RC	14- 18	3/4-1
	550 - 1000 CCA	85-190RC	18-35	1 -2
MARINE/DEEP CYCLE		80 RC	18	NR
		140 RC	27	NR
		160 RC	30	NR
		180 RC	33	NR

The Hydrometer or Electronic Method

To find the time needed to fully charge your battery, determine the battery's charge level with a hydrometer or electronic Percent-of-Charge Tester. The following table will help you convert hydrometer readings to percent of charge values.

SPECIFIC GRAVITY	PERCENT OF CHARGE	PERCENT OF CHARGE NEEDED
1.265	100%	0%
1.225	75%	25%
1.155	25%	75%
1.120	0%	100%

When you know the percent of charge and the Amp Hour (AH) rating of your battery, you can calculate the time needed to bring your battery to a full charge.

To convert Reserve Capacity to Amp Hours, divide Reserve Capacity by 2, and add 16:

$$\text{Amp Hours} = \frac{\text{Reserve Capacity} + 16}{2}$$

To calculate time needed for a charge;

- Find the percent of charge needed. (A battery at 50 percent charge that will be charged to 100 percent needs another 50 percent (.50).
- Multiply the Amp Hour rating by the charge needed (.50) and divide by the charger setting (2 or 40 amps),
- Multiply the result by 1.25 and you'll have the time need, in hours, to bring the battery to full charge.
- Add one more hour for a deep-cycle battery.

Example:

$$\frac{\text{Amp Hour Rating} \times \% \text{ of charge needed} \times 1.25}{\text{Charger Setting}} = \text{hours of charge needed}$$

$$\frac{100 \text{ (AH Rating)} \times .50 \text{ (charge needed)} \times 1.25}{40 \text{ (Charger Setting)}} = 1.5625 \text{ hours}$$

$$\frac{100 \times .50}{40} = 1.25 \times 1.25 = 1.5625$$

You would need to charge your 100-Ampere Hour Battery for a little more than 1.5 hours at the 40-Amp charge rate using the above example.

Using the engine start feature

Your battery charger can be used to jump-start your car if the battery is low. Follow these instructions on how to use the engine start feature.

1. Set the right-hand OUTPUT SELECTOR switch to the OFF position. Then follow the instructions for connecting the charger to the battery in the section "Charging your battery in the vehicle" see page 7.
2. Once the charger is connected, set the right-hand selector switch to SELECT and set the left selector switch to the 200 AMP START position.
3. Plug in the charger.
4. Crank the engine for no more than five seconds. If the engine does not start, wait four minutes before cranking again.
5. During extremely cold weather, or if the battery is severely exhausted, charge the battery for about five minutes before cranking the engine.

6. If the engine still does not start, charge the battery for five more minutes in the 40 amp position before cranking it again for five seconds.
7. After the engine starts, unplug the charger power cord from the outlet. Then move the right-hand OUTPUT SELECTOR SWITCH to the OFF position before disconnecting the battery leads.

IMPORTANT: Do not try to start the engine without a battery in it. You could cause damage to the electrical system.

If the engine does turn over, but never starts up, there is not a problem with the starting system, there is a problem somewhere else with the vehicle. **STOP** cranking the engine until the other problem has been diagnosed and corrected.

Maintenance and care

A minimal amount of care can keep your battery charger working properly for years.

1. Clean the clamps each time you are finished charging. Wipe off any battery fluid that may have come in contact with the clamps to prevent corrosion.
2. Coil the input and output cords neatly when storing the charger. The cords can be wrapped around the handle of the charger. This will help prevent accidental damage to the cords and charger.
3. Occasional cleaning of the case with a soft cloth will keep the finish shiny and help prevent corrosion.

Troubleshooting

Performance problems often result from little things that you can fix yourself. Please read through this chart for a possible solution if a problem occurs.

PROBLEM	POSSIBLE CAUSE	SOLUTION/REASONS
No reading on the ammeter.	Clamps are not making a good connection. 2-amp charge rate is being used.	Check for poor connections to battery and frame. Make sure connecting points are clean. Ammeter may show no activity at the 2-amp charge rate.
No reading on ammeter. Fan inside wheel charger appears to be not working.	No power at receptacle AC cord and/or extension cord is loose.	Check for open fuse or circuit breaker supplying AC outlet. Check power cord and extension cord for loose fitting plug.
Circuit breaker in charger cycles on and off with a clicking sound.	Shorted battery clamps. Shorted battery. Charger leads reversed. Volt/Amp Selector Switch set to the START position.	Circuit breaker cycles when current draw is too high. Separate the clamps. Check for worn cables and replace if needed. Have a Sears technician test the battery. Correct connections. Correct Volt/Amp Selector setting.
Short start cycle when cranking engine.	Drawing more than 200 amps for a period of 5 seconds or less. Failure to wait for 4 minutes (240 seconds) between cranks.	Crank time varies with the amount of current drawn. If cranking draws more than 200 amps, crank time may be less than 5 seconds. Wait 4 minutes before next crank.
Ammeter reads less than selected charge rate when charging a discharged battery.	Extension cord too long or wire gauge too small. Weak cell or sulfated plate in battery. Battery is only partially discharged.	Use shorter or heavier gauge extension cord. Sulfated battery will eventually take a normal charge if left connected. If the battery will not take a charge, have it tested by a Sears technician. Continue to charge battery.
Charger makes a loud buzz or hum.	Transformer laminations vibrate (buzz). Shorted diode (hum).	Continue charging. Buzz is not abnormal. Have charger tested by qualified technician.

If the above solutions do not eliminate the problem...
call toll-free from anywhere in the U.S.A.
1-800-SEARS-64
(1-800-732-7764)
7 AM to 4:30 PM CST Monday through Friday

SEARS

OWNER'S MANUAL

Model No.
200.71440

40/2 AMP MANUAL BATTERY CHARGER

200 AMP ENGINE STARTER

For information about troubleshooting

Call toll-free from anywhere in the U.S.A.

7 am to 4:30 pm CST Monday through Friday

1-800-SEARS-64

(1-800-732-7764)

For the repair or replacement parts you need

Call 7 am - 7 pm, 7 days a week

1-800-366-PART

(1-800-366-7278)



For the location of a Sears Repair Service Center in your area

Call 24 hours a day,

7 days a week

1-800-488-1222



When requesting service or
ordering parts, always provide
the following information:

- Product Type
- Model Number
- Part Number
- Part Description

SEARS

REPAIR SERVICES

America's Repair Specialists